



US 20190131379A1

(19) **United States**

(12) **Patent Application Publication**
Won et al.

(10) **Pub. No.: US 2019/0131379 A1**
(43) **Pub. Date: May 2, 2019**

(54) **DISPLAY DEVICE AND METHOD OF MANUFACTURING THE SAME**

Publication Classification

(71) Applicant: **LG DISPLAY CO., LTD.**, Seoul (KR)

(51) **Int. Cl.**
H01L 27/32 (2006.01)
H01L 51/52 (2006.01)

(72) Inventors: **Sanghyuk Won**, Paju-si (KR); **MinJoo Kim**, Paju-si (KR); **JaeWon Lee**, Paju-si (KR); **SangHoon Pak**, Paju-si (KR); **Byonghoo Kim**, Paju-si (KR); **Sangheun Lee**, Paju-si (KR); **Hyangmyoung Gwon**, Paju-si (KR); **Jeonghoon Lee**, Paju-si (KR); **Sungjin Kim**, Paju-si (KR); **Jaehyung Jang**, Paju-si (KR); **Yuna Lee**, Paju-si (KR)

(52) **U.S. Cl.**
CPC **H01L 27/3276** (2013.01); **H01L 51/5284** (2013.01); **G06F 3/0412** (2013.01); **H01L 27/323** (2013.01); **H01L 27/3246** (2013.01); **H01L 51/5253** (2013.01)

(73) Assignee: **LG DISPLAY CO., LTD.**, Seoul (KR)

(57) **ABSTRACT**

(21) Appl. No.: **16/176,061**

A display device includes a first substrate where a display area and a non-display area are defined, wherein a plurality of pixels are arranged at the display area and the non-display area surrounds the display area; a dam surrounding the display area and arranged at the non-display area; an organic light emitting diode provided in the display area; an encapsulation film disposed on the organic light emitting diode; a buffer layer disposed on the encapsulation film; an insulating film disposed on the buffer layer; a pad area arranged outside the dam, wherein the buffer layer and the insulating film extend from the display area to the pad area; a link line disposed between the dam and the first substrate; and a routing line provided on the insulating layer between the display area and the pad area.

(22) Filed: **Oct. 31, 2018**

(30) **Foreign Application Priority Data**

Oct. 31, 2017 (KR) 10-2017-0143995

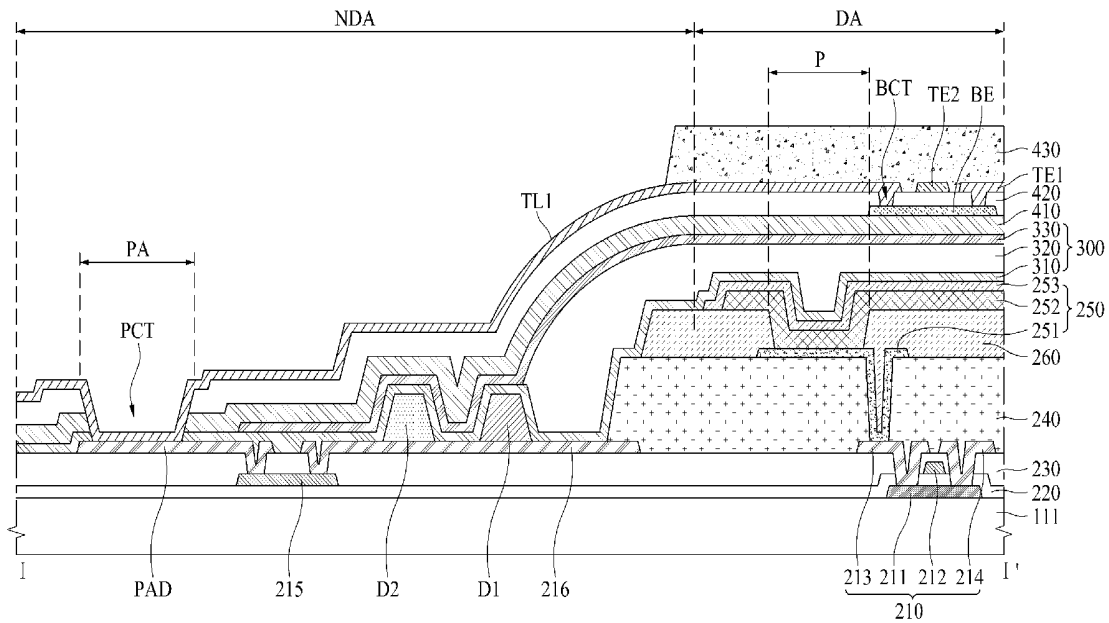

FIG. 1

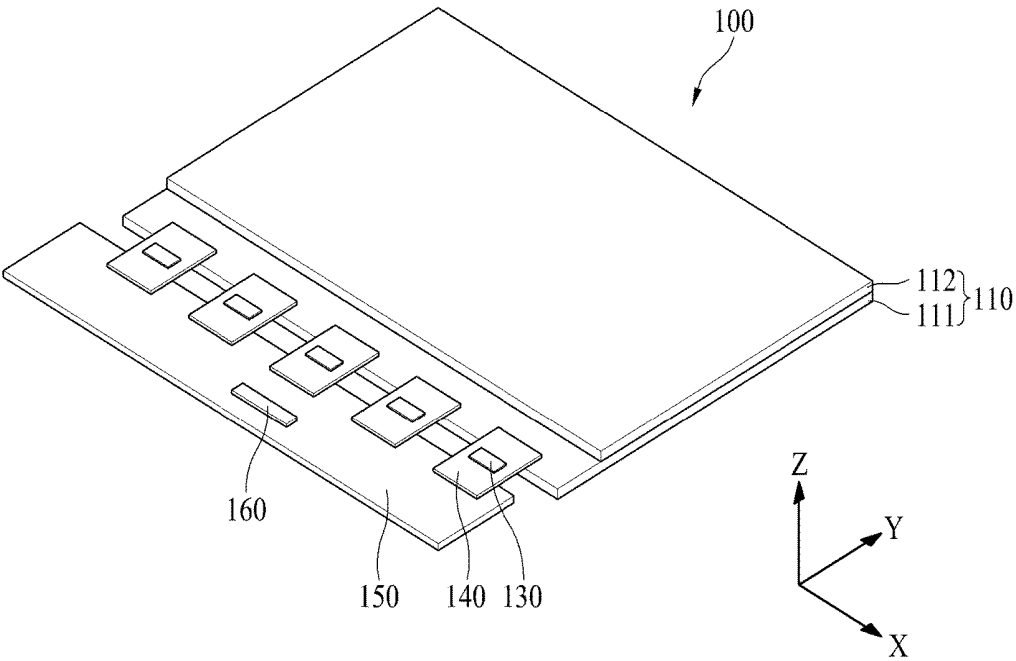

FIG. 2

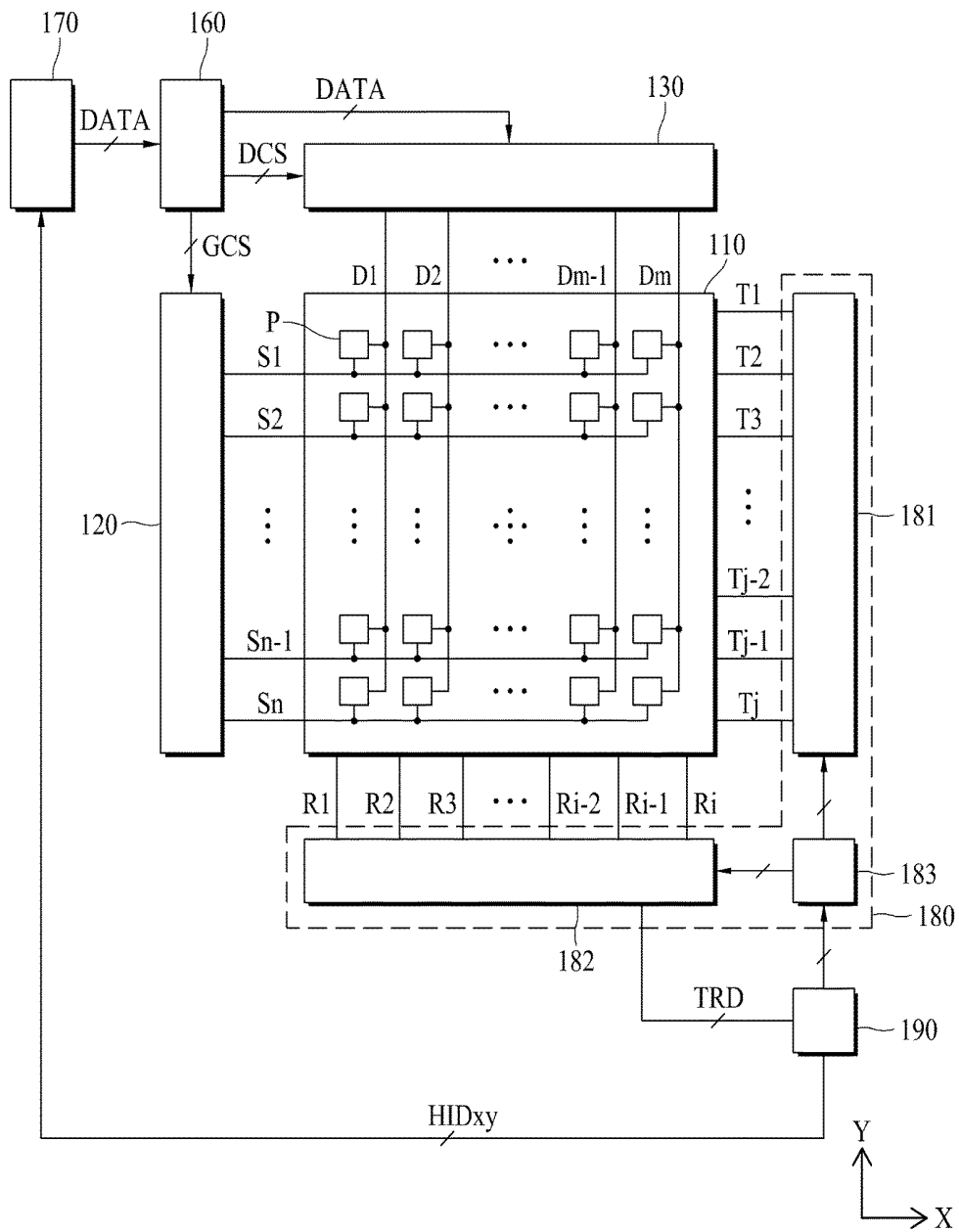

FIG. 3

110

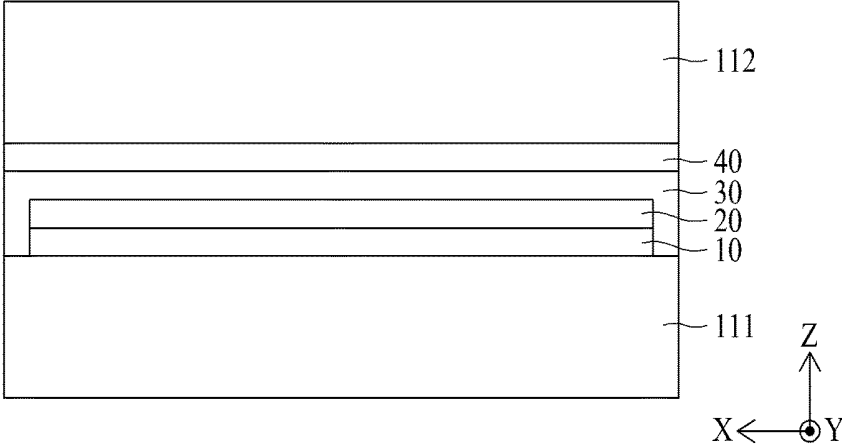

FIG. 4

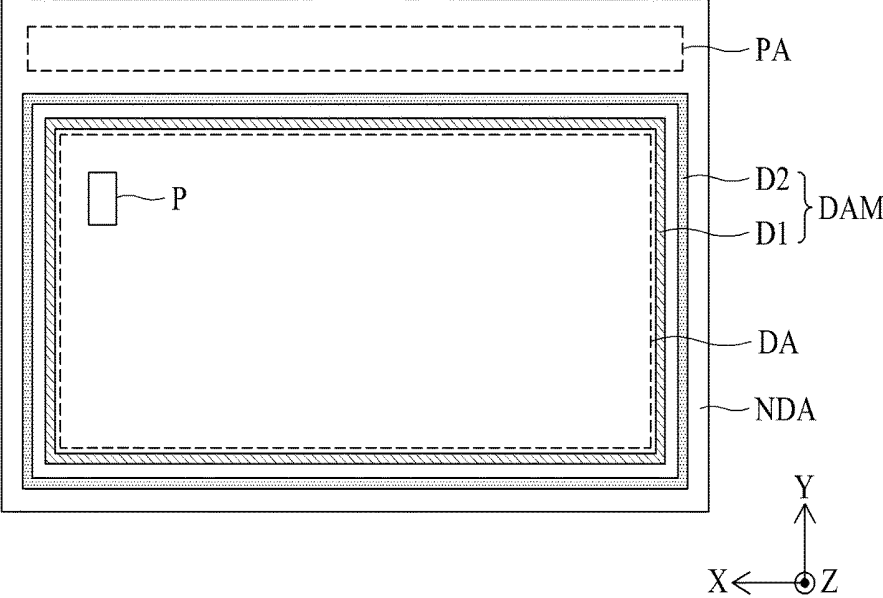

FIG. 5

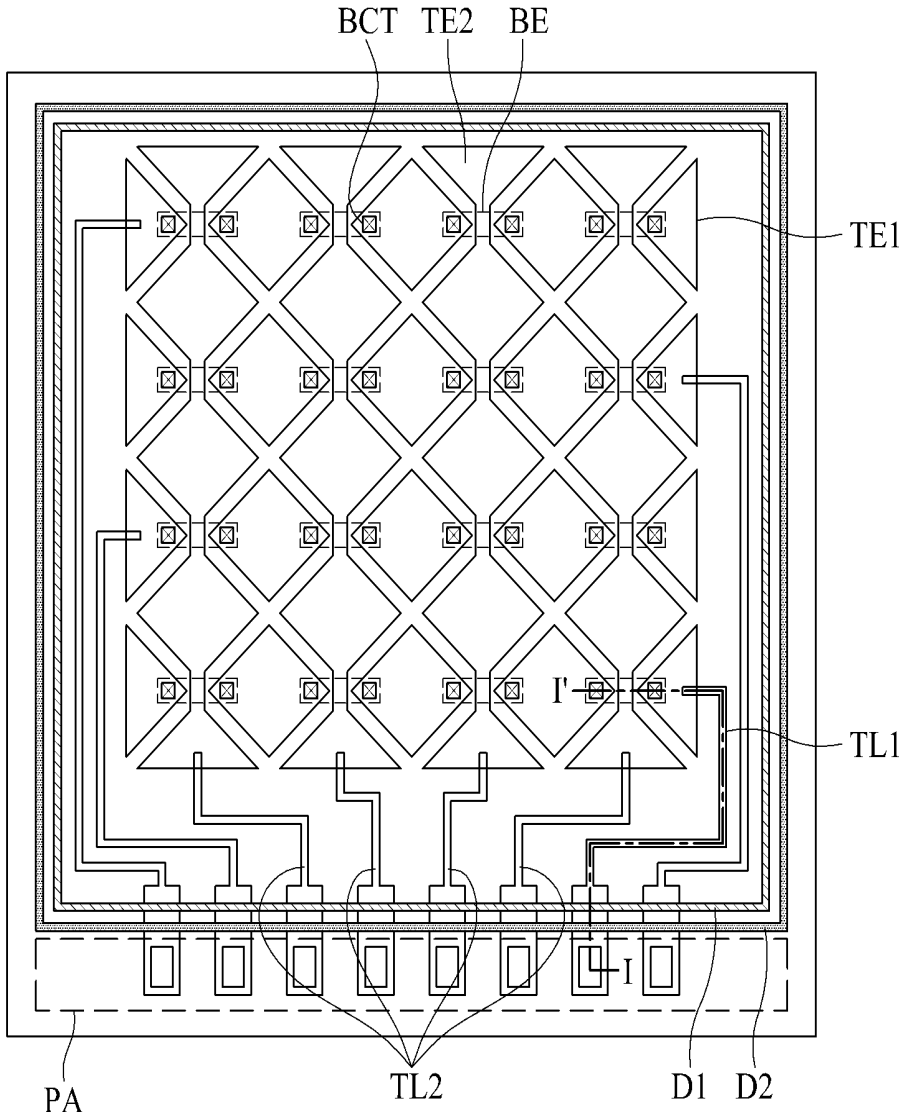

FIG. 7

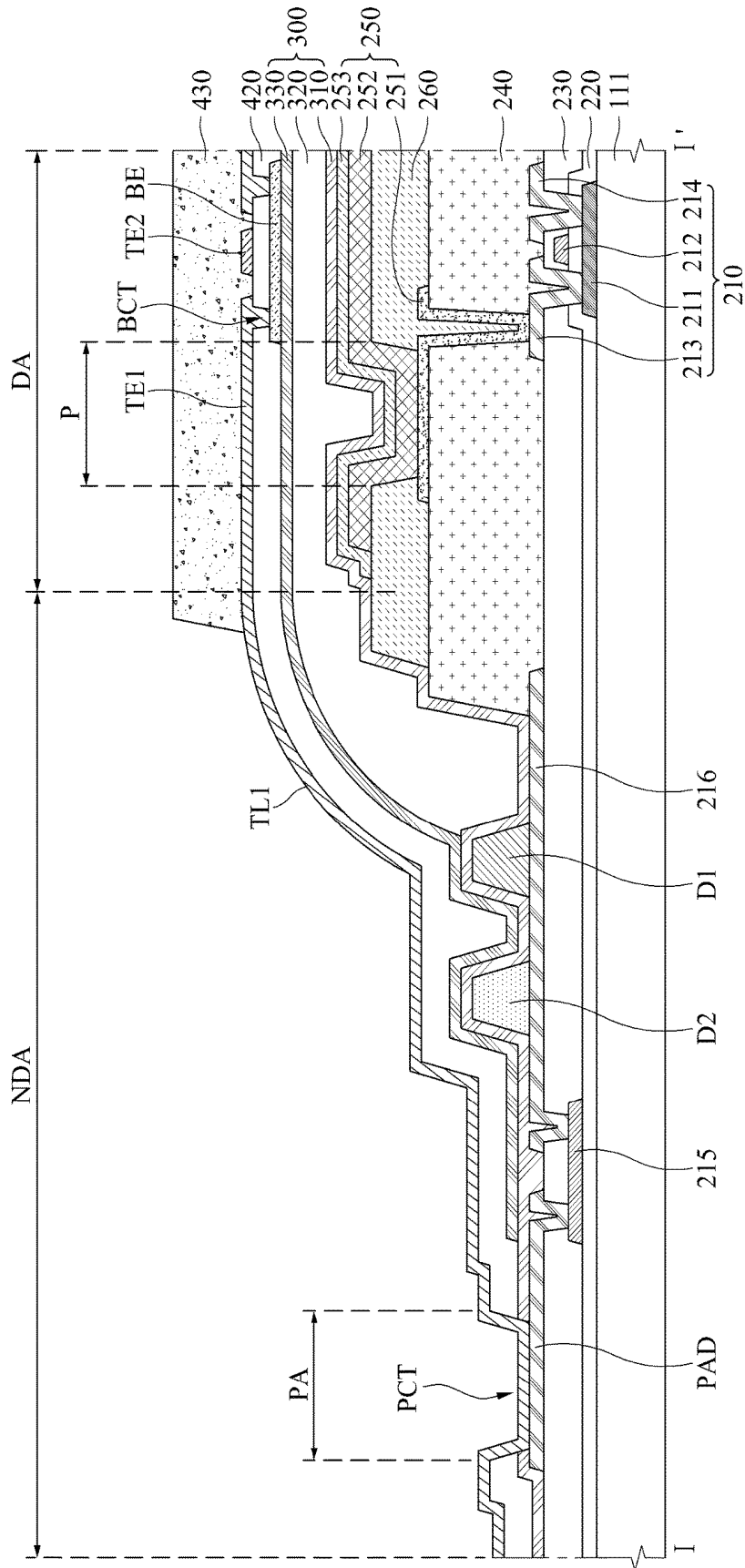

FIG. 8

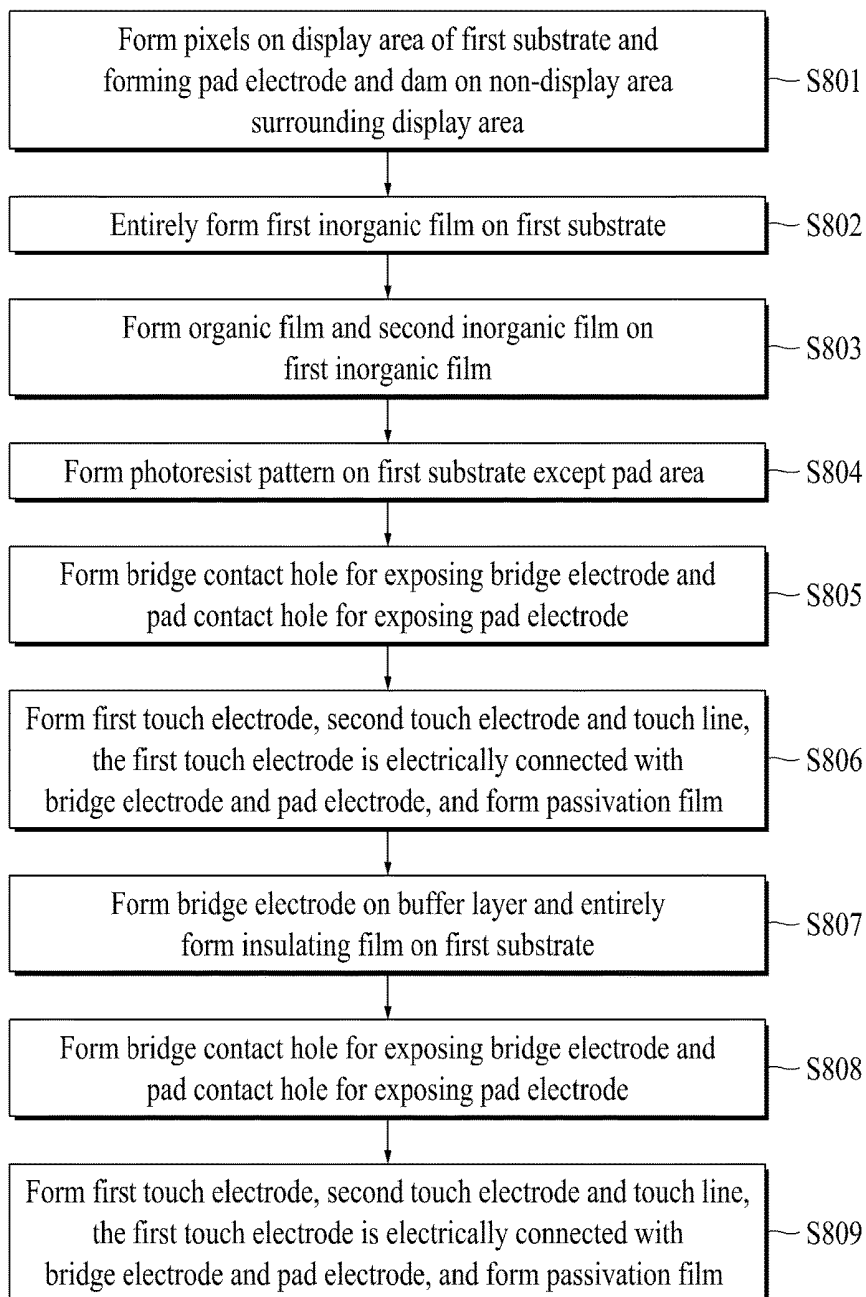

FIG. 9A

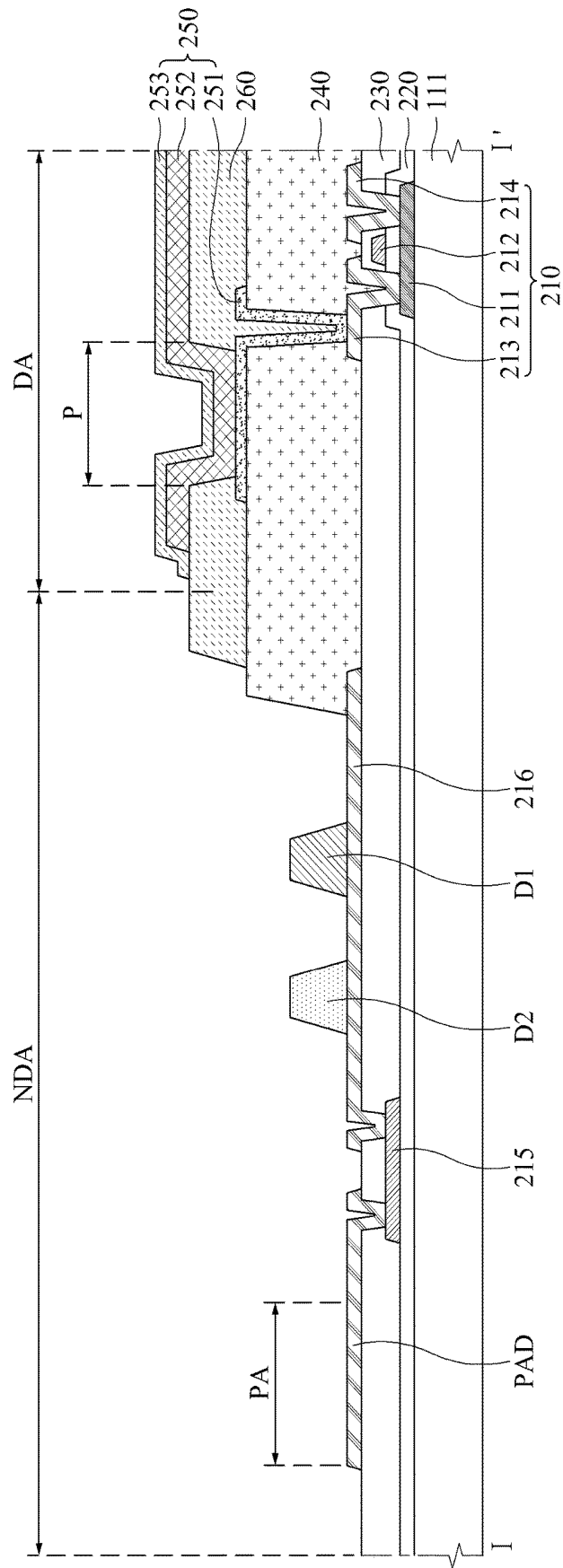

FIG. 9B

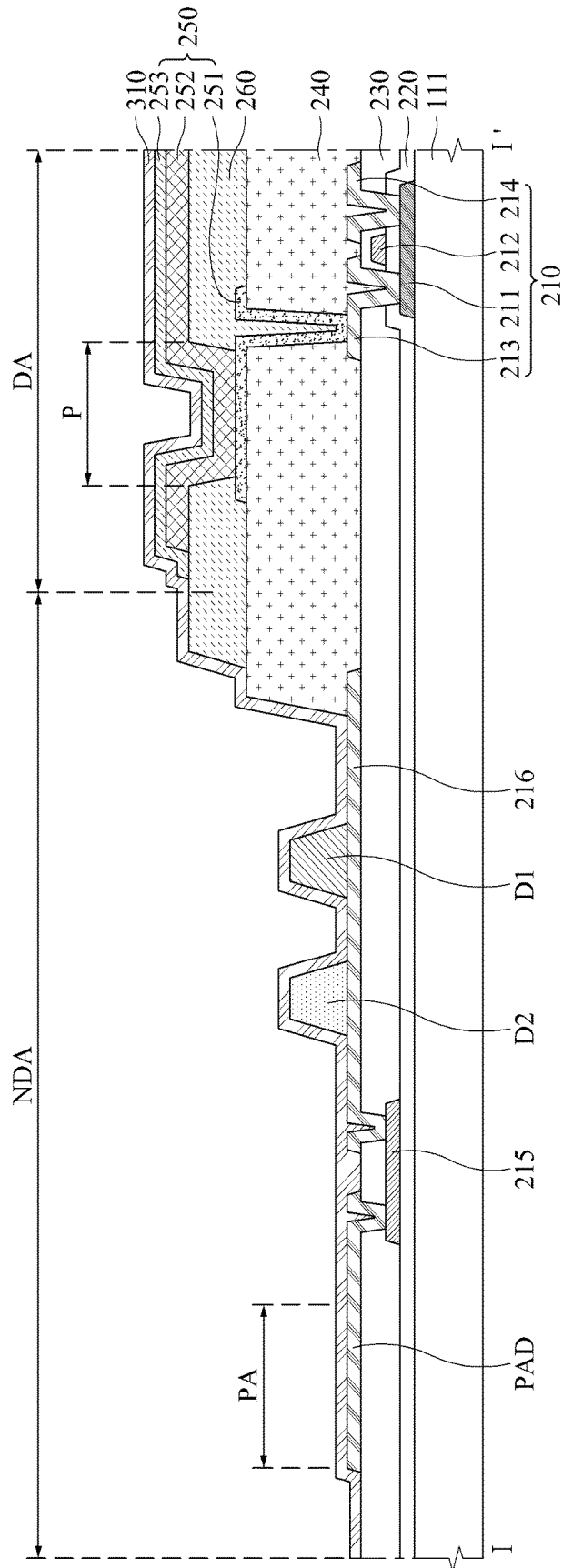

FIG. 9D

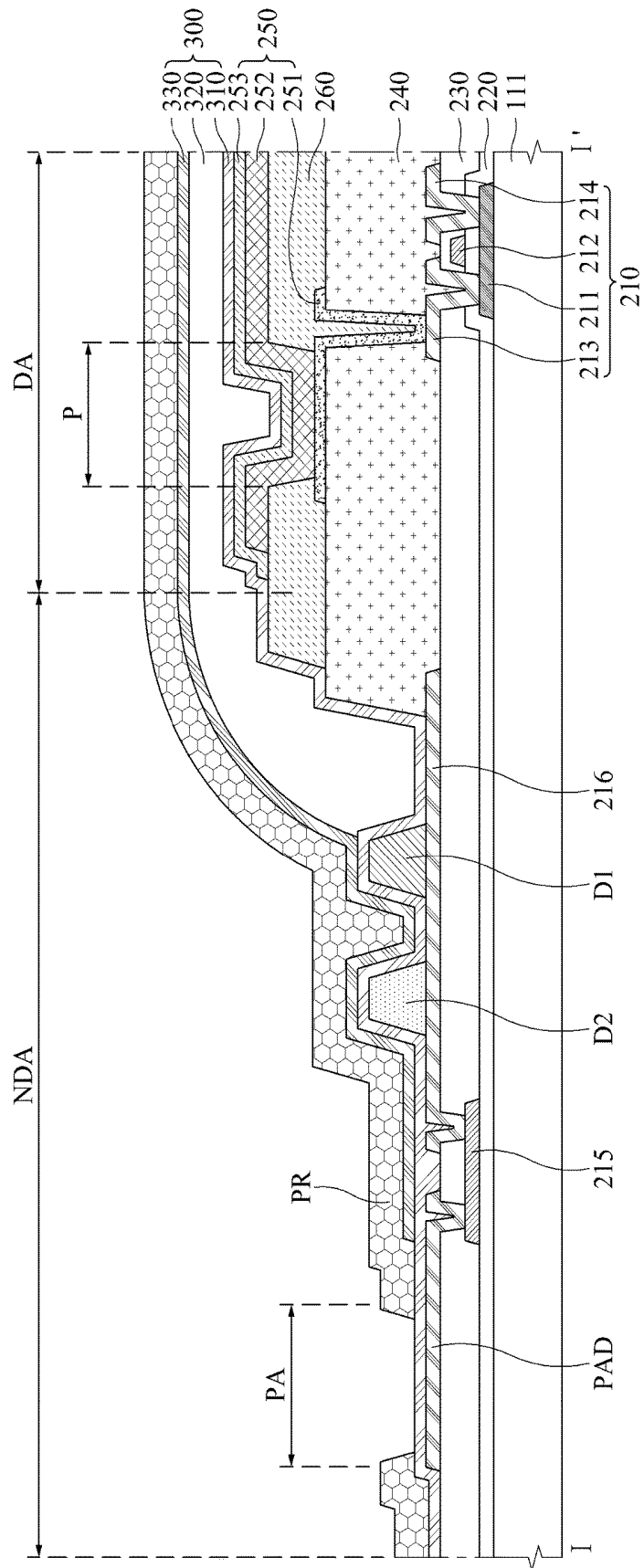

FIG. 9E

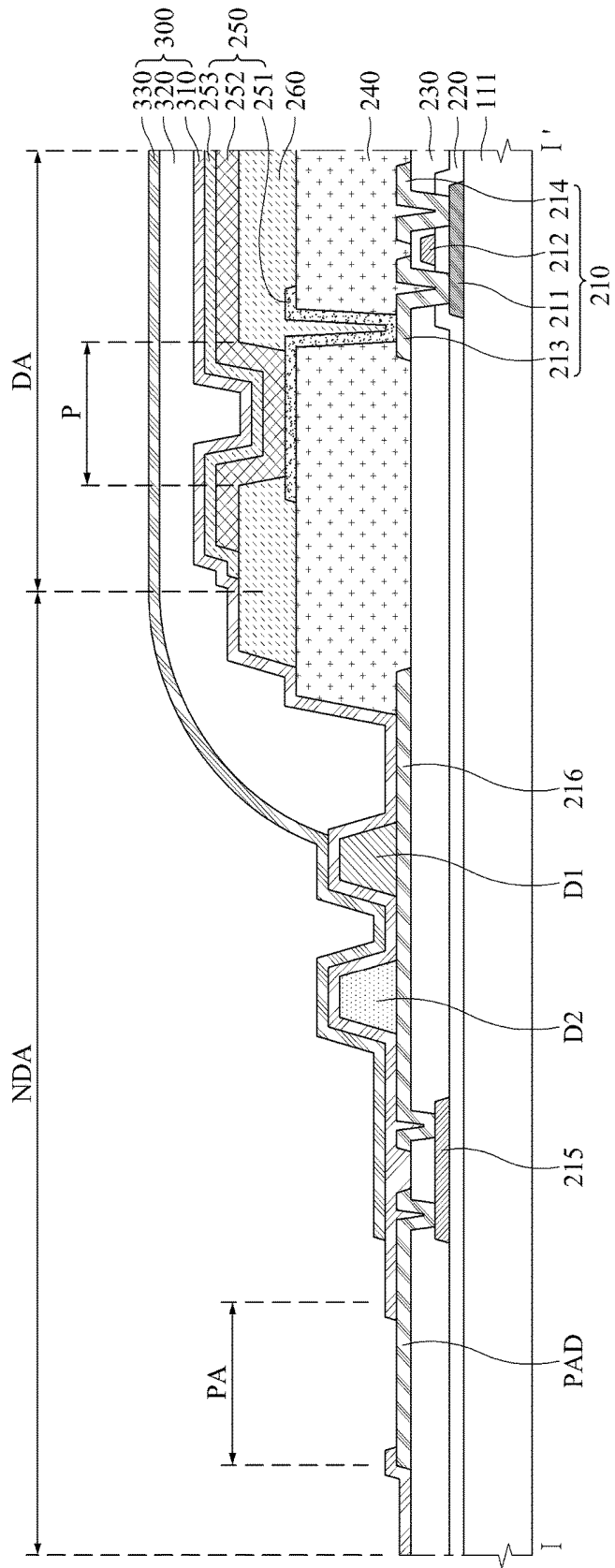

FIG. 9F

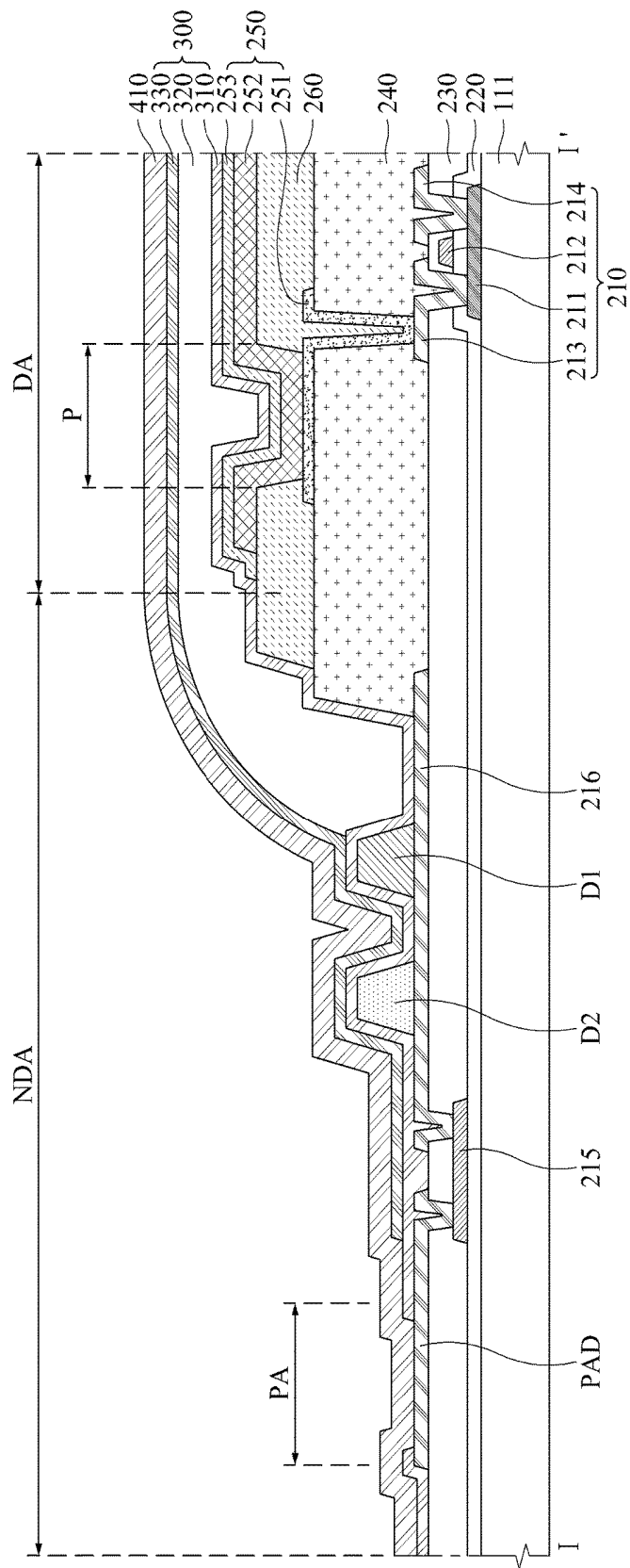

FIG. 10

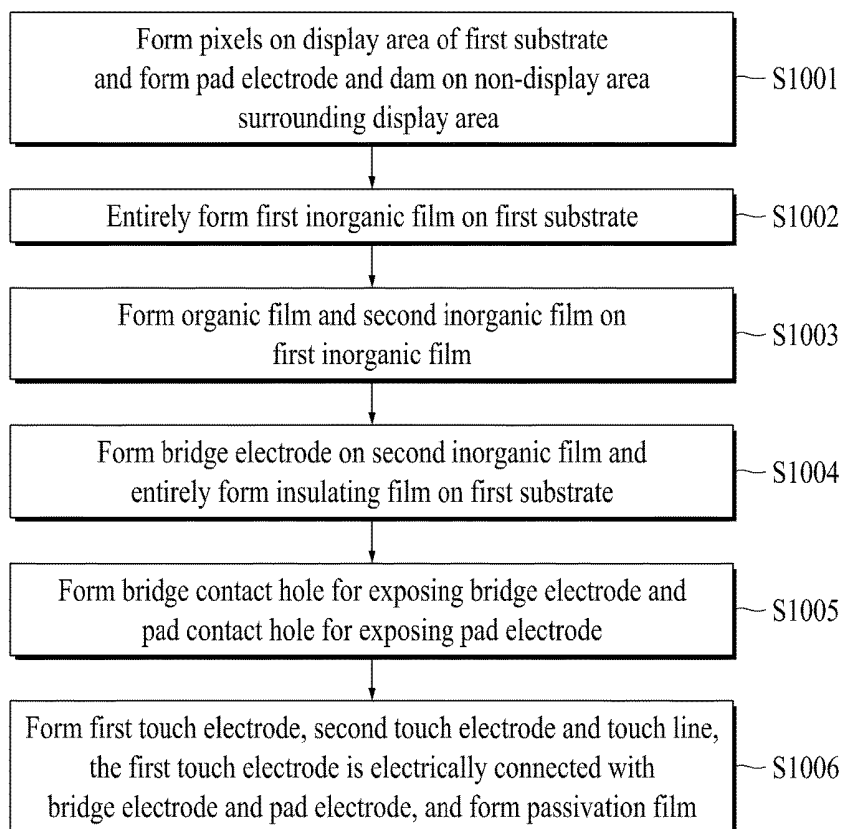

FIG. 11C

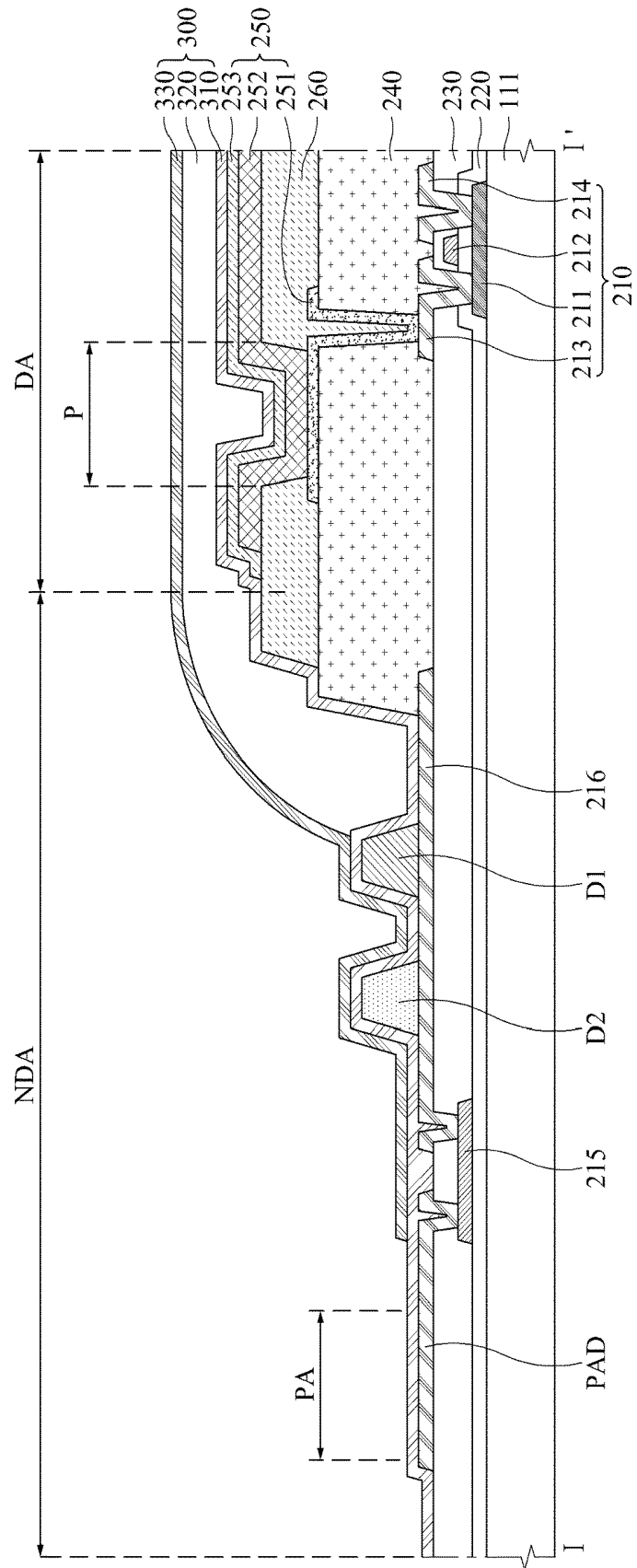
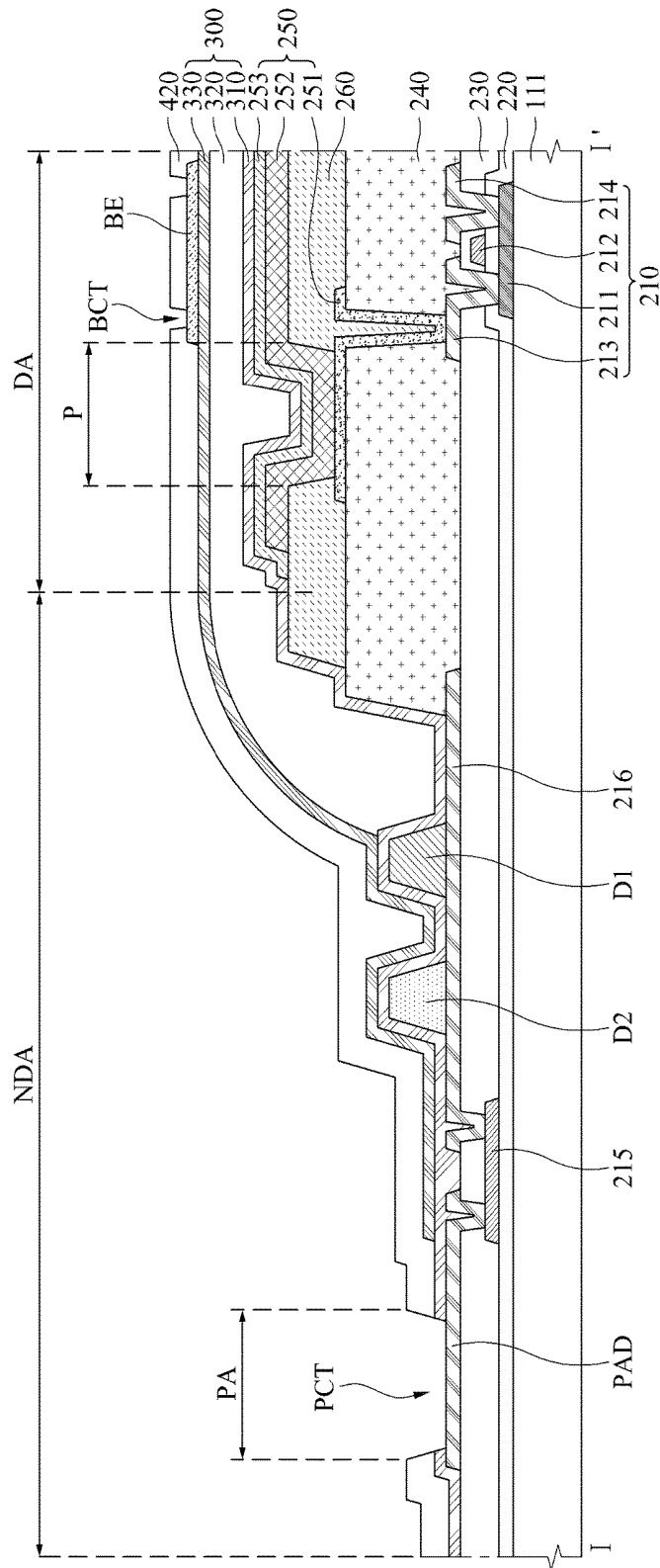

FIG. 11E



DISPLAY DEVICE AND METHOD OF MANUFACTURING THE SAME

CROSS-REFERENCE TO RELATED APPLICATION

[0001] This application claims priority to Korean Patent Application No. 10-2017-0143995, filed on Oct. 31, 2017, the disclosure of which is incorporated herein by reference in its entirety.

BACKGROUND

Field of the Disclosure

[0002] The present disclosure relates to a display device and a method of manufacturing the same.

Description of the Background

[0003] With the advancement of the information age, a demand for a display device for displaying an image has been increased in various forms. Therefore, various display devices such as liquid crystal display (LCD) devices, plasma display panel (PDP) devices, and organic light emitting display (OLED) devices have been used.

[0004] Among the display devices, the organic light emitting display device is a self-light emitting device, and has advantages in that a viewing angle and a contrast ratio are more excellent than those of the liquid crystal display (LCD) device. Also, since the organic light emitting display device does not require a separate backlight, it is advantageous that the organic light emitting display device is able to be thin and lightweight and has low power consumption. Furthermore, the organic light emitting display device has advantages in that it may be driven at a low direct current voltage, has a fast response speed, and especially has a low manufacturing cost.

[0005] However, the organic light emitting display device includes pixels, each of which includes an organic light emitting diode, and has a disadvantage in that the organic light emitting diode may be easily degraded by external factors such as external water and oxygen. In order to prevent this, the organic light emitting display device forms an encapsulation film to prevent external water and oxygen from being permeated into the organic light emitting diode.

[0006] The encapsulation film includes at least one inorganic film and at least one organic film to prevent oxygen or water from being permeated into an organic light emitting layer and an electrode. At this time, at least one organic film generally includes a polymer, and is formed by a hardening process after being doped on a substrate in a liquid type. Since such an organic film has flexibility until the hardening process is performed, a problem may occur in that the organic film may overflow outside an area where the encapsulation film is to be formed. For example, the organic film may overflow toward a pad area where a plurality of pads is provided. To solve this problem, a dam for blocking a flow of the organic film is formed along the outside of the organic light emitting diode.

[0007] Also, to protect the organic light emitting diode from oxygen or water, at least one inorganic film is entirely formed on the organic light emitting diode except a pad area where a pad electrode is arranged. In the manufacturing method of the related art, to expose the pad electrode, a mask for covering the pad electrode is arranged on the pad

electrode, and then the inorganic film is formed. The mask is arranged to be close to the pad electrode such that the inorganic film is not formed in the pad area. At this time, arcing may occur between a boundary surface of the mask for covering the pad area and the pad electrode. If arcing occurs between the mask and the pad electrode, a high current entering the pad electrode from the mask may flow into the display device along the pad electrode, whereby a defect may occur.

SUMMARY

[0008] Accordingly, the present disclosure is directed to a display device and a method of manufacturing the same, which substantially obviate one or more problems due to limitations and disadvantages of the related art.

[0009] In addition, the present disclosure is to provide a display device and a method of manufacturing the same preventing arcing at the boundary of the mask and the pad electrode of the display device.

[0010] Additional advantages and features of the disclosure will be set forth in part in the description which follows and in part will become apparent to those having ordinary skill in the art upon examination of the following or may be learned from practice of the disclosure. The objectives and other advantages of the disclosure may be realized and attained by the structure particularly pointed out in the written description and claims hereof as well as the appended drawings.

[0011] To achieve the above features, the present disclosure provides a display device and a method of manufacturing the same, wherein the display device comprises a first substrate including a display area on which pixels are arranged, and a non-display area surrounding the display area; a dam surrounding the display area, arranged on the non-display area; a pad electrode arranged outside the dam; and an encapsulation film covering the display area and including a first inorganic film, wherein the first inorganic film surrounds or at least partially covers the pad electrode.

[0012] It is to be understood that both the foregoing general description and the following detailed description of the present disclosure are exemplary and explanatory and are intended to provide further explanation of the disclosure as claimed.

BRIEF DESCRIPTION OF THE DRAWINGS

[0013] The accompanying drawings, which are included to provide a further understanding of the disclosure and are incorporated in and constitute a part of this application, illustrate example(s) of the disclosure and together with the description serve to explain the principle of the disclosure.

[0014] In the drawings:

[0015] FIG. 1 is a perspective view illustrating a display device according to one example of the present disclosure;

[0016] FIG. 2 is a block view illustrating a display device according to one example of the present disclosure;

[0017] FIG. 3 is a cross-sectional view briefly illustrating one side of a display panel in FIG. 1;

[0018] FIG. 4 is a plane view briefly illustrating a first substrate according to one example of the present disclosure;

[0019] FIG. 5 is a plane view illustrating a touch sensing layer arranged on the first substrate;

[0020] FIG. 6 is a cross-sectional view illustrating a first example taken along line I-I' of FIG. 5;

[0021] FIG. 7 is a cross-sectional view illustrating a second example taken along line I-I' of FIG. 5;

[0022] FIG. 8 is a flow chart illustrating a method of manufacturing a display device according to the first example of the present disclosure;

[0023] FIG. 9A is a cross-sectional view illustrating a method of manufacturing a display device according to the first example of the present disclosure;

[0024] FIG. 9B is a cross-sectional view illustrating a method of manufacturing a display device according to the first example of the present disclosure;

[0025] FIG. 9C is a cross-sectional view illustrating a method of manufacturing a display device according to the first example of the present disclosure;

[0026] FIG. 9D is a cross-sectional view illustrating a method of manufacturing a display device according to the first example of the present disclosure;

[0027] FIG. 9E is a cross-sectional view illustrating a method of manufacturing a display device according to the first example of the present disclosure;

[0028] FIG. 9F is a cross-sectional view illustrating a method of manufacturing a display device according to the first example of the present disclosure;

[0029] FIG. 9G is a cross-sectional view illustrating a method of manufacturing a display device according to the first example of the present disclosure;

[0030] FIG. 9H is a cross-sectional view illustrating a method of manufacturing a display device according to the first example of the present disclosure;

[0031] FIG. 9I is a cross-sectional view illustrating a method of manufacturing a display device according to the first example of the present disclosure;

[0032] FIG. 10 is a flow chart illustrating a method of manufacturing a display device according to the second example of the present disclosure;

[0033] FIG. 11A is a cross-sectional view illustrating a method of manufacturing a display device according to the second example of the present disclosure;

[0034] FIG. 11B is a cross-sectional view illustrating a method of manufacturing a display device according to the second example of the present disclosure;

[0035] FIG. 11C is a cross-sectional view illustrating a method of manufacturing a display device according to the second example of the present disclosure;

[0036] FIG. 11D is a cross-sectional view illustrating a method of manufacturing a display device according to the second example of the present disclosure;

[0037] FIG. 11E is a cross-sectional view illustrating a method of manufacturing a display device according to the second example of the present disclosure; and

[0038] FIG. 11F is a cross-sectional view illustrating a method of manufacturing a display device according to the second example of the present disclosure.

DETAILED DESCRIPTION

[0039] Terms disclosed in this specification should be understood as follows.

[0040] The term of a singular expression should be understood to include a multiple expression as well as the singular expression if there is no specific definition in the context. The terms such as “the first” and “the second” are used only to differentiate one element from other elements. Thus, a scope of claims is not limited by these terms. Also, it should be understood that the term such as “include” or “have” does

not preclude existence or possibility of one or more features, numbers, steps, operations, elements, parts or their combinations. It should be understood that the term “at least one” includes all combinations related with any one item. For example, “at least one among a first element, a second element and a third element” may include all combinations of two or more elements selected from the first, second and third elements as well as each element of the first, second and third elements. Also, if it is mentioned that a first element is positioned “on or above” a second element, or “over” a second element, it should be understood that the first and second elements may be brought into contact with each other, or a third element may be interposed between the first and second elements.

[0041] Hereinafter, a display device and a method of manufacturing the same according to an example of the present disclosure will be described with reference to the accompanying drawings. Wherever possible, the same reference numbers will be used throughout the drawings to refer to the same or like parts. Also, in the following description of the present disclosure, if detailed description of elements or functions known in respect of the present disclosure is determined to make the subject matter of the present disclosure unnecessarily obscure, the detailed description will be omitted.

[0042] FIG. 1 is a perspective view illustrating a display device according to one example of the present disclosure. FIG. 2 is a block view illustrating a display device according to one example of the present disclosure.

[0043] Referring to FIGS. 1 and 2, the display device according to the example of the present disclosure includes a display panel 110, a scan driver 120, a data driver 130, a timing controller 160, a host system 170, a touch driver 180, and a touch coordinate calculator 190.

[0044] The display device with a built-in touch screen according to the example of the present disclosure may be realized as a flat panel display device such as a Liquid Crystal Display (LCD), Field Emission Display (FED), Plasma Display Panel (PDP), Organic Light Emitting Display (OLED), and Electrophoresis display (EPD). Hereinafter, the display device with a built-in touch screen according to the example of the present disclosure is realized as, but not limited to, an organic light emitting display device.

[0045] The display panel 110 includes a display area on which pixels P are arranged to display an image. On the display area 110, data lines D1 to Dm (m is a positive integer of 2 or more) and scan lines S1 to Sn (n is a positive integer of 2 or more) are provided. The data lines D1 to Dm may be formed to cross the scan lines S1 to Sn. The pixels P may be formed on the area defined by a crossed structure of the gate lines and data lines.

[0046] Each of the pixels P of the display panel 110 may be connected to any one of the data lines D1 to Dm and any one of the scan lines S1 to Sn. Each of the pixels P of the display panel 110 may include a driving transistor for controlling a drain-source current in accordance with a data voltage applied to a gate electrode, a scan transistor turned on by a scan signal of the scan line, supplying a data voltage of the data line to the gate electrode of the driving transistor, an organic light emitting diode for emitting light in accordance with the drain-source current of the driving transistor, and a capacitor for storing a voltage of the gate electrode of

the driving transistor. Therefore, each of the pixels P may emit light in accordance with the current supplied to the organic light emitting diode.

[0047] The scan driver 120 receives a scan control signal GCS from the timing controller 160. The scan driver 120 supplies scan signals to the scan lines S1~Sn in accordance with the scan control signal GCS.

[0048] The scan driver 120 may be formed in a non-display area outside one side or both sides of a display area of the display panel 110 in a GIP (gate driver in panel) mode. Alternatively, the scan driver 120 is fabricated of a driving chip, packaged in a flexible film, and may be attached to the non-display area outside one side or both sides of the display area of the display panel 110 in a TAB (tape automated bonding) mode.

[0049] The data driver 130 receives digital video data DATA and a data control signal DCS from the timing controller 160. The data driver 130 converts the digital video data DATA into an analogue positive polarity/negative polarity data voltage in accordance with the data control signal DCS and supplies them to the data lines. That is, pixels to which the data voltages will be supplied are selected by the scan signals of the scan driver 120, and the data voltages are supplied to the selected pixels.

[0050] The data driver 130 may include a plurality of source drive ICs. Each of the plurality of source drive ICs may be packaged into the flexible film 140 in a COF (chip on film) or COP (chip on plastic) mode. The flexible film 140 is attached onto pads provided on the non-display area of the display panel 110 using an anisotropic conducting film, whereby the source drive ICs may be connected to the pads.

[0051] The circuit board 150 may be attached to the flexible films 140. A plurality of circuits realized as driving chips may be packaged onto the circuit board 150. For example, the timing controller 160 may be packaged onto the circuit board 150. The circuit board 150 may be a printed circuit board or flexible printed circuit board.

[0052] The timing controller 160 receives digital video data DATA and timing signals from the host system 170. The timing signals may include a vertical synchronization signal, a horizontal synchronization signal, a data enable signal, and a dot clock. The vertical synchronization signal is a signal defining one frame period. The horizontal synchronization signal is a signal defining one horizontal period needed to supply the data voltages to pixels of one horizontal line of the display panel DIS. The data enable signal is a signal for defining a period of inputting available data. The dot clock is a signal repeated with a predetermined short period.

[0053] In order to control operation timings of the scan driver 120 and the data driver 130, the timing controller 160 generates a data control signal DCS to control operation timing of the data driver 130 and a scan control signal GCS for controlling operation timing of the scan driver 120 based on the timing signals. The timing controller 160 outputs the scan control signal GCS to the scan driver 120 and outputs the digital video data DATA and the data control signal DCS to the data driver 130.

[0054] The host system 170 may be realized as a navigation system, a set-top box, a DVD player, a blue-ray player, a personal computer (PC), a home theater system, a broadcasting receiver, and a phone system. The host system 170 includes SoC (System on chip) equipped with a scaler and converts the digital video data DATA of an input image to a format suitable to display the display panel 110. The host

system 170 transmits the digital video data DATA and the timing signals to the timing controller 160.

[0055] On the display panel 110, not only the data lines D1 to Dm and the scan lines S1 to Sn but also first and the second touch electrodes may be formed. The first touch electrodes may be formed to cross the second touch electrodes. The first touch electrodes may be connected to a first touch driver 181 through first touch lines T1 to Tj, where j is an integer equal to or greater than 2. The second touch electrodes may be connected to a second touch driver 182 through second touch lines R1 to Ri, where i is an integer equal to or greater than 2. On each of the intersections between the first touch electrodes and the second touch electrodes, a touch sensor may be formed. The touch sensor according to the example of the present disclosure is realized as, but not limited to, a mutual capacitance. The first and the second touch electrodes will be described later in more detail with reference to FIG. 4.

[0056] The touch driver 180 supplies a driving pulse to the first touch electrodes through the first touch lines T1 to Tj and senses the amount of charge changes in each of the touch sensors through the second touch lines R1 to Ri. That is, in FIG. 2, description will be given based on that the first touch lines T1 to Tj are Tx lines for supplying a driving pulse and the second touch lines R1 to Ri are Rx lines for sensing the amount of charge changes in each of the touch sensors.

[0057] The touch driver 180 includes the first touch driver 181, the second touch driver 182, and the touch controller 183. The first touch driver 181, the second touch driver 182, and the touch controller 183 may be integrated into one ROIC (Read-out IC).

[0058] The first touch driver 181 selects the first touch line to output a driving pulse under the control of the touch controller 183 and supplies the driving pulse to the selected first touch line. For example, the first touch driver 181 may sequentially supply driving pulses to the first touch lines T1 to Tj.

[0059] The second touch driver 182 selects the second touch lines to receive the amount of charge changes in the touch sensors under the control of the touch controller 183 and receives the amount of charge changes in the touch sensors through the selected second touch lines. The second touch driver 182 converts the amount of charge changes in the touch sensors, which are received through the second touch lines R1 to Ri, to touch raw data TRD corresponding to digital data, by sampling the amount of charge changes in the touch sensors.

[0060] The touch controller 183 may generate a Tx setup signal in the first touch driver 181 to set up the first touch line to which the driving pulse is to be output and an Rx setup signal in the second touch line to set up the second touch line in which a touch sensor voltage is to be received. Also, the touch controller 183 generates timing control signals to control operation timings of the first touch driver 181 and the second touch driver 182.

[0061] The touch coordinate calculator 190 receives touch raw data TRD from the touch driver 180. The touch coordinate calculator 190 calculates touch coordinates in accordance with a touch coordinate calculating method and outputs touch coordinate data HIDxy including information of touch coordinates to the host system 170.

[0062] The touch coordinate calculator 190 may be realized as a Micro Controller Unit (MCU). The host system 170 analyzes touch coordinate data HIDxy input from the touch

coordinate calculator **190** and executes an application program connected with a coordinate where a touch is generated by a user. The host system **170** transmits the digital video data DATA and the timing signals to the timing controller **160** in accordance with the executed application program.

[0063] The touch driver **180** may be included in the source drive ICs **131** or may be fabricated of a separate drive chip and packaged onto the circuit board **150**. Also, the touch coordinate calculator **190** may be fabricated of a driving chip and packaged onto the circuit board **150**.

[0064] FIG. 3 is a cross-sectional view briefly illustrating one side of a display panel in FIG. 1.

[0065] Referring to FIG. 3, the display panel **110** may include a first substrate **111**, a second substrate **112**, a thin film transistor layer **10** arranged between the first and second substrates **111** and **112**, an organic light emitting diode layer **20**, an encapsulation layer **30**, and a touch sensing layer **40**.

[0066] The first substrate **111** may be a plastic film or a glass substrate.

[0067] The thin film transistor layer **10** is formed on the first substrate **111**. The thin film transistor layer **10** may include scan lines, data lines, and thin film transistors. Each of the thin film transistors includes a gate electrode, a semiconductor layer, source and drain electrodes. In the case that a scan driver is formed using a GIP (gate driver in panel) method, the scan driver may be formed together with the thin film transistor layer **10**.

[0068] The organic light emitting diode layer **20** is formed on the thin film transistor **10**. The organic light emitting diode layer **20** includes first electrodes, an organic light emitting layer, a second electrode, and banks. Each of the organic light emitting layers may include a hole transporting layer, an organic light emitting layer, and an electron transporting layer. In this case, when a voltage is applied to the first electrode and the second electrode, holes and electrons are moved to the light emitting layer through the hole transporting layer and the electron transporting layer, respectively and are combined in the organic light emitting layer, thereby emitting light. Since pixels P are arranged on the area where the organic light emitting diode layer **20** is arranged, the area where the organic light emitting diode layer **20** is arranged may be defined as the display area. An area in the periphery of the display area may be defined as the non-display area.

[0069] The encapsulation layer **30** is formed on the organic light emitting diode layer **20**. The encapsulation layer **30** serves to prevent oxygen and water from being permeated into the organic light emitting diode layer **20**. The encapsulation layer **30** includes at least one inorganic film.

[0070] The touch sensing layer **40** is formed on the encapsulation layer **30**. The touch sensing layer **40** includes first and the second touch electrodes for sensing a touch of a user, and may include bridge electrodes for electrically connecting the first touch electrodes or the second touch electrodes.

[0071] Hereafter, the encapsulation layer **30** and the touch sensing layer **40** according to the first example of the present disclosure will be described in more detail with reference to FIGS. 4 to 11.

[0072] FIG. 4 is a plane view briefly illustrating a first substrate according to one example of the present disclosure, FIG. 5 is a plane view illustrating a touch sensing layer arranged on the first substrate, FIG. 6 is a cross-sectional

view illustrating a display device according to the first example of the present disclosure, illustrating a first example taken along line I-I' of FIG. 5.

[0073] Referring to FIGS. 4 to 6, the first substrate **111** is categorized into a display area DA and a non-display area NDA, wherein pixels P are arranged on the display area DA. The non-display area NDA surrounds the display area DA, and is provided with a pad area PA where pad electrodes PAD are formed. Also, a dam DAM is formed on the non-display area NDA.

[0074] The thin film transistor layer **10** and the organic light emitting diode layer **20** are formed on the first substrate **111**.

[0075] The thin film transistor layer **10** includes thin film transistors **210**, a gate insulating film **220**, an inter-layer dielectric film **230**, and a planarization film **240**.

[0076] A buffer film may be arranged on one surface of the first substrate **111**. The buffer film may be formed on one surface of the first substrate **111** to protect the thin film transistors **210** and light emitting diodes **260** from water permeated through the first substrate **111** which is vulnerable to moisture permeability. One surface of the first substrate **111** may be a surface facing the second substrate **112**. The buffer film may be made of a plurality of inorganic films which are deposited alternately. For example, the buffer film may be formed of a multi-layered film of one or more inorganic films of a silicon oxide film (SiOx), a silicon nitride film (SiNx) and SiON, which are deposited alternately. The buffer film may be omitted.

[0077] The thin film transistor **210** is arranged on the buffer film. The thin film transistor **210** includes an active layer **211**, a gate electrode **212**, a source electrode **213**, and a drain electrode **214**. Although the thin film transistor **210** is formed in a top gate mode in which the gate electrode **212** is arranged above the active layer **211** as shown in FIG. 6, it is to be understood that the thin film transistor of the present disclosure is not limited to the top gate mode. That is, the thin film transistor **210** may be formed in a bottom gate mode in which the gate electrode **212** is arranged below the active layer **211** or a double gate mode in which the gate electrode **212** is arranged above and below the active layer **211**.

[0078] The active layer **211** is arranged on the first substrate **111**. The active layer **211** may be formed of a silicon-based semiconductor material or an oxide-based semiconductor material. A light-shielding layer for shielding external light entering the active layer **211** may be formed between the first substrate **111** and the active layer **211**.

[0079] The gate insulating film **220** may be arranged on the active layer **211**. The gate insulating film **220** may be formed of an inorganic film, for example, a silicon oxide film (SiOx), a silicon nitride film (SiNx) or a multi-layered film of the silicon oxide film and the silicon nitride film.

[0080] The gate electrode **212** and the gate line **215** may be arranged on the gate insulating film **220**. The gate electrode **212** and the gate line **215** may be formed of a single layer or multi-layer comprised of any one of Mo, Al, Cr, Au, Ti, Ni, Nd and Cu or their alloy.

[0081] The inter-layer dielectric film **230** may be arranged on the gate electrode **212** and the gate line **215**. The inter-layer dielectric film **230** may be formed of an inorganic film, for example, a silicon oxide film (SiOx), a silicon nitride film (SiNx), or a multi-layered film of the silicon oxide film and the silicon nitride film.

[0082] The source electrode 213, the drain electrode 214 the source-drain line 216 and the pad electrode PAD may be arranged on the inter-layer dielectric film 230. Each of the source electrode 213 and the drain electrode 214 may be connected to the active layer 211 through a contact hole that passes through the gate insulating film 220 and the inter-layer dielectric film 230. Also, the source-drain line 216 and the pad electrode PAD may be connected to the gate line 215 through a contact hole that passes through the inter-layer dielectric film 230. The source electrode 213, the drain electrode 214, the source-drain line 216 and the pad electrode PAD may be formed of a single layer or multi-layer comprised of any one of Mo, Al, Cr, Au, Ti, Ni, Nd and Cu or their alloy.

[0083] A passivation film may be formed on the source electrode 213 and the drain electrode 214 to insulate the thin film transistor 210. The passivation film may be formed of an inorganic film, for example, a silicon oxide film (SiO_x), a silicon nitride film (SiN_x), or a multi-layered film of the silicon oxide film and the silicon nitride film.

[0084] The planarization film 240 for planarizing a step difference due to the thin film transistor 210 may be arranged on the source electrode 213 and the drain electrode 214. The planarization film 240 may be formed of an organic film such as acrylic resin, epoxy resin, phenolic resin, polyamide resin, and polyimide resin.

[0085] The organic light emitting diode layer 20 is arranged on the thin film transistor layer 10. The organic light emitting diode layer 20 includes an organic light emitting diode 250 and a bank 260.

[0086] The organic light emitting diode 250 and the bank 260 are arranged on the planarization film 240. The organic light emitting diode 250 includes the first electrode 251, the organic light emitting layer 252, and the second electrode 253. The first electrode 251 may be an anode electrode, and the second electrode 253 may be a cathode electrode.

[0087] The first electrode 251 may be formed on the planarization film 240. The first electrode 251 may be connected to the source electrode 213 of the thin film transistor 210 through a contact hole that passes through the passivation film and the planarization film 240. The first electrode 251 may be formed of conductive material with high reflexivity such as a deposition structure (Ti/Al/Ti) of Al and Ti, a deposition structure (ITO/Al/ITO) of Al and ITO, an APC alloy, or a deposition structure (ITO/APC/ITO) of APC alloy and ITO. The APC alloy is an alloy of Ag, Pd and Cu.

[0088] In order to partition pixels P, the bank 260 may be arranged on the planarization film 240 to cover an edge of the first electrode 251. That is, the bank 260 serves as a pixel defining film for defining pixels P. The bank 260 may be formed of an organic film such as acrylic resin, epoxy resin, phenolic resin, polyamide resin, and polyimide resin.

[0089] The organic light emitting layer 252 is arranged on the first electrode 251 and the bank 260. The organic light emitting layer 252 may include a hole transporting layer, at least one light emitting layer, and an electron transporting layer. In this case, when a voltage is applied to the first electrode 251 and the second electrode 253, holes and electrons are moved to the light emitting layer through the hole transporting layer and the electron transporting layer, respectively, and are combined in the organic light emitting layer to emit light.

[0090] The organic light emitting layer 252 may be formed of a white light emitting layer for emitting white light. In this case, the organic light emitting layer 252 may be arranged to cover the first electrode 251 and the bank 260. In this case, a color filter (not shown) may be formed on the second substrate 112.

[0091] Otherwise, the organic light emitting layer 252 may be formed of a red light emitting layer for emitting red light, a green light emitting layer for emitting green light, and a blue light emitting layer for emitting blue light. In this case, the organic light emitting layer 252 may be arranged on the area corresponding to the first electrode 251 and a color filter may not be arranged on the second substrate 112.

[0092] The second electrode 253 is arranged on the organic light emitting layer 252. In the case that the organic light emitting display device is formed in a top emission structure, the second electrode 253 may be formed of a transparent conductive material (TCO) such as ITO and IZO, which may transmit light, or a semi-transmissive conductive material such as Mg, Ag, and alloy of Mg and Ag. A capping layer may be arranged on the second electrode 253.

[0093] On the organic light emitting diode layer 20, the encapsulation layer 20 is formed not only on the display area DA but also on the non-display area NDA. The encapsulation layer 30 includes a dam DAM and an encapsulation film 300.

[0094] The dam DAM is arranged on the non-display area NDA and blocks a flow of an organic film 320 constituting the encapsulation film 300. In more detail, the dam DAM is arranged to surround the outside of the display area DA and blocks a flow of the organic film 320 constituting the encapsulation film 300. The dam DAM may also be arranged on the non-display area NDA to block the flow of the organic film 320, thereby allowing the organic film 320 constituting the encapsulation film 300 not to be permeated into the pad electrode PAD exposed by a pad contact hole PCT. Therefore, the dam DAM may prevent the organic film 320 from being exposed to the outside of the display device or from being permeated into the pad electrode PAD.

[0095] Such a dam DAM may include a first dam D1 and a second dam D2.

[0096] The first dam D1 may be arranged to surround the outside of the display area DA to primarily block the flow of the organic film 320 constituting the encapsulation film 300. Also, the first dam D1 may be arranged between the display area DA and the pad area PA to primarily block the flow of the organic film 320 by preventing the organic film 320 from being permeated into the exposed pad electrode PAD.

[0097] The second dam D2 is arranged to surround the outside of the first dam D1, and is spaced apart from the first dam D1 and arranged in parallel with the first dam D1. The second dam D2 may secondarily block the flow of the organic film 320 toward the outside of the first dam D1. Therefore, the first dam D1 and the second dam D2 may more effectively prevent the organic film 320 from being exposed to the outside of the display device or from being permeated into the exposed pad electrode PAD.

[0098] Such a dam DAM may be formed simultaneously with the planarization film 240 or the bank 260 and formed of the same material as that of the planarization film 240 or the bank 260. In this case, the dam DAM may be formed of an organic film such as acrylic resin, epoxy resin, phenolic resin, polyamide resin, and polyimide resin.

[0099] The encapsulation film 300 serves to prevent oxygen or water from being permeated into the organic light emitting layer 252 and the second electrode 253. To this end, the encapsulation film 300 may include at least one inorganic film and at least one organic film. For example, the encapsulation film 300 may include a first inorganic film 310, the organic film 320, and a second inorganic film 330.

[0100] The first inorganic film 310 is arranged on the second electrode 253. The first inorganic film 310 is arranged to cover the second electrode 253. The first inorganic film 310 according to the first example of the present disclosure covers the second electrode 253 and is extended to the non-display area NDA to cover the dam DAM. Also, after fabrication is complete, the first inorganic film 310 according to the first example of the present disclosure is extended to the pad area PA arranged outside the dam DAM but exposes the pad electrode PAD without fully covering the pad electrode PAD. At this time, the first inorganic film 310 according to the first example of the present disclosure surrounds (e.g. at least partially covers) the pad electrode PAD, and more specifically is arranged to cover the region of the pad electrode PAD outside of the pad contact hole PCT for exposing the pad electrode PAD.

[0101] In the display device 100 according to the first example of the present disclosure, since the first inorganic film 310 is extended to the pad area PA, it is not required to arrange a mask for covering the pad electrode PAD on the pad electrode PAD so as not to form the first inorganic film 310 on the pad area PA. Therefore, in the display device 100 according to the first example of the present disclosure, a mask is not arranged on the pad electrode PAD to prevent arcing from being generated between a boundary surface of the mask and the pad electrode and prevent a defect from being generated due to a high current from the mask, which flows into the display device along the pad electrode PAD.

[0102] As described above, in the display device 100 according to the first example of the present disclosure, the first inorganic film 310 is entirely formed to cover the pad electrode PAD, and the organic film 320 and the second inorganic film 330 are formed and then the pad contact hole PCT is formed by an etching process using a photoresist.

[0103] The organic film 320 is arranged on the first inorganic film 310. The organic film 320 may be formed with a suitable thickness to prevent particles from being permeated into the organic light emitting layer 252 and the second electrode 253 by passing through the first inorganic film 310. The organic film 320 may be hardened by a hardening process after being deposited in a liquid type through an inkjet process.

[0104] The second inorganic film 330 is arranged on the organic film 320. The second inorganic film 330 is arranged to cover the organic film 320. The second inorganic film 330 according to the first example of the present disclosure covers the organic film 320 and may be extended to the non-display area NDA to cover the dam DAM. At this time, the second inorganic film 330 according to the first example of the present disclosure is not formed on the pad area PA. That is, the first inorganic film 310 and the second inorganic film 330 according to the first example of the present disclosure are formed to have their respective ends located to be different from each other.

[0105] When forming the second inorganic film 330 according to the first aspect of the present disclosure, a mask may be arranged over the pad electrode PAD. At this time,

in the display device 100 according to the first example of the present disclosure, since the first inorganic film 310 is formed on the pad electrode PAD, arcing is not generated between the boundary surface of the mask and the pad electrode PAD even though the mask is arranged over the pad electrode PAD. That is, the first inorganic film 310 serves as an insulating film between the mask and the pad electrode PAD. In this way, in the display device 100 according to the first example of the present disclosure, since the first inorganic film 310 formed to reach the pad area PA serves as an insulating film, arcing is not generated between the boundary surface of the mask and the pad electrode PAD even though the mask is arranged over the pad electrode PAD during a manufacturing process of the second inorganic film 330.

[0106] Each of the first and second inorganic films 310 and 330 may be formed of a silicon nitride, an aluminum nitride, a zirconium nitride, a titanium nitride, a hafnium nitride, a tantalum nitride, a silicon oxide, an aluminum oxide, or a titanium oxide. The organic film 320 may be formed of acrylic resin, epoxy resin, phenolic resin, polyamide resin, or polyimide resin.

[0107] The touch sensing layer 40 is formed on the encapsulation layer 30. The touch sensing layer 40 includes a buffer layer 410, bridge electrodes BE, an insulating film 420, first touch electrodes TE1, second touch electrodes TE2, and a passivation film 430.

[0108] The buffer layer 410 is formed on the encapsulation layer 30. The buffer layer 410 is formed to cover the encapsulation film 300. The buffer layer 410 according to the first example of the present disclosure covers the encapsulation film 300, and is extended to the non-display area NDA to cover the dam DAM. Also, the buffer layer 410 according to the first example of the present disclosure is extended to the pad area PA arranged outside the dam DAM but exposes the pad electrode PAD without covering the pad electrode PAD. At this time, the buffer layer 410 according to the first example of the present disclosure surrounds the pad electrode PAD, and more specifically is arranged to surround the outside of the pad contact hole PCT for exposing the pad electrode PAD.

[0109] In the display device 100 according to the first example of the present disclosure, since the buffer layer 410 is formed to be extended to the pad area PA, the pad electrode PAD may be prevented from being damaged when the bridge electrode BE is formed on the buffer layer 410. In more detail, the bridge electrode BE is formed on the buffer layer 410, and in this case, if the pad electrode PAD is exposed, the pad electrode PAD may be damaged. In the display device 100 according to the first example of the present disclosure, the buffer layer 410 is formed to be extended to the pad area PA, and the bridge electrode BE is formed, whereby the pad electrode PAD may be prevented from being damaged.

[0110] The bridge electrode BE is formed on the buffer layer 410. In order to prevent the first touch electrodes TE1 and the second touch electrodes TE2 from short-circuiting at their crossing areas, the bridge electrode BE electrically connects the first touch electrodes TE1 adjacent to each other in a first direction. The bridge electrode BE is formed on a different layer from the first and second touch electrodes TE1 and TE2, and may be connected to the first touch

electrodes TE1 adjacent to each other through bridge contact holes BCT. The bridge electrode BE may cross the second touch electrode TE2.

[0111] The insulating film 420 is arranged on the bridge electrode BE. The insulating film 420 is arranged to cover the bridge electrode BE, thereby insulating the bridge electrode BE from the first and second touch electrodes TE1 and TE2. The insulating film 420 according to the first example of the present disclosure covers the bridge electrode BE, and is extended to the non-display area NDA, whereby the insulating film may be formed to reach the pad area PA. Also, the insulating film 420 according to the first example of the present disclosure is extended to the pad area PA arranged outside the dam DAM but exposes the pad electrode PAD without covering the pad electrode PAD. At this time, the insulating film 420 according to the first example of the present disclosure surrounds the pad electrode PAD, and more specifically is arranged to surround the outside of the pad contact hole PCT for exposing the pad electrode PAD.

[0112] In the display device 100 according to the first example of the present disclosure, since the insulating film 420 is extended to the pad area PA, it is not required to arrange a mask for covering the pad electrode PAD on the pad electrode PAD so as not to form the insulating film 420 on the pad area PA.

[0113] The buffer layer 410 and the insulating film 420 formed on the pad electrode PAD may be removed simultaneously to expose the pad electrode PAD during the process of forming the bridge contact hole BCT. That is, the bridge contact hole BCT and the pad contact hole PCT may be formed at the same time.

[0114] The first touch electrodes TE1 and the second touch electrodes TE2 are arranged on the insulating film 420. The first touch electrodes TE1, the second touch electrodes TE2, the first touch lines TL1 and the second touch lines TL2 may be arranged on the same layer. The first touch electrodes TE1 are arranged in a first direction (y-axis direction) and connected to each other, and the second touch electrodes TE2 are arranged in a second direction (x-axis direction) and connected to each other. The first direction (y-axis direction) may be parallel with the scan lines S1 to Sn, and the second direction (x-axis direction) may be parallel with the data lines D1 to Dm. Alternatively, the first direction (y-axis direction) may be parallel with the data lines D1 to Dm, and the second direction (x-axis direction) may be parallel with the scan lines S1 to Sn.

[0115] Each of the first touch electrodes TE1 connected in the first direction (y-axis direction) is electrically insulated from the first touch electrodes TE1 adjacent thereto in the second direction (x-axis direction). Each of the second touch electrodes TE2 connected in the second direction (x-axis direction) is electrically insulated from the second touch electrodes TE2 adjacent thereto in the first direction (y-axis direction).

[0116] For this reason, mutual capacitance corresponding to the touch sensor may be formed on the crossed area of the first touch electrode TE1 and the second touch electrode TE2.

[0117] Among the first touch electrodes TE1 connected with each other in the first direction (y-axis direction), the first touch electrode TE1 arranged at one end may be connected to the first touch line TL1 on the non-display area NDA. The first touch line TL1 may be extended from the

first touch electrode TE1 and then patterned to reach the pad area PA. The first touch line TL1 may be connected to the pad electrode PAD in the pad area PA and then connected to the first touch driver 181 through the pad electrode PAD. Therefore, the first touch electrodes TE1 connected with each other in the first direction (y-axis direction) may receive a driving pulse from the first touch driver 181 through the first touch line TL1.

[0118] Among the second touch electrodes TE2 connected with each other in the second direction (x-axis direction), the second touch electrode TE2 arranged at one end may be connected to the second touch line TL2 on the non-display area NDA. The second touch line TL2 may be extended from the second touch electrode TE2 and then patterned to reach the pad area PA. The second touch line TL2 may be connected to the pad electrode PAD on the pad area PA and then connected to the second touch driver 182 through the pad electrode PAD. Therefore, the second touch driver 182 may receive amount of charge changes in the touch sensors of the second touch electrodes TE2 connected with each other in the second direction (x-axis direction).

[0119] The passivation film 430 is formed on the first touch electrodes TE1 and the second touch electrodes TE2. The passivation film 430 maintains characteristic stabilization of the display device by blocking a harmful environment from the outside. Also, the passivation film 430 may be formed not only on the first touch electrodes TE1 and the second touch electrodes TE2 but also between the first touch electrodes TE1 and the second touch electrodes TE2. Each of the first touch electrodes TE1 may be insulated from each of the second touch electrodes TE2 by the passivation film 430.

[0120] According to the example of the present disclosure, since the touch sensing layer is directly formed on the encapsulation layer 30, it is not required to align the first substrate 111 and the second substrate 112 when the first substrate 111 and the second substrate 112 are bonded to each other.

[0121] As described above, in the display device 100 according to the first example of the present disclosure, since the first inorganic film 310 is extended to the pad area PA, it is not required to arrange a mask for covering the pad electrode PAD on the pad electrode PAD so as not to form the first inorganic film 310 on the pad area PA.

[0122] Therefore, in the display device 100 according to the first example of the present disclosure, a mask is not arranged on the pad electrode PAD to prevent arcing from being generated between a boundary surface of the mask and the pad electrode and prevent a defect from being generated due to a high current from the mask, which flows into the display device 100 along the pad electrode PAD.

[0123] FIG. 7 is a cross-sectional view illustrating a display device according to the second example of the present disclosure, illustrating a second example taken along line I-I' of FIG. 5. The display device 100 shown in FIG. 7 is the same as the display device 100 according to the first example described in FIG. 6 except a manufacturing method of a pad contact hole PCT according to omission of a buffer layer. Therefore, the manufacturing method of the pad contact hole PCT will be described, and a repeated description of the same elements will be omitted.

[0124] Referring to FIG. 7, the first inorganic film 310 of the display device 100 according to the second example of the present disclosure is arranged on the second electrode

253. The first inorganic film **310** is arranged to cover the second electrode **253**. The first inorganic film **310** according to the second example of the present disclosure covers the second electrode **253** and is extended to the non-display area NDA to cover the dam DAM. Also, the first inorganic film **310** according to the second example of the present disclosure is extended to the pad area PA arranged outside the dam DAM but exposes the pad electrode PAD without covering the pad electrode PAD. At this time, the first inorganic film **310** according to the second example of the present disclosure surrounds (e.g. at least partially covers) the pad electrode PAD, and more specifically is arranged to surround the outside of the pad contact hole PCT for exposing the pad electrode PAD.

[0125] In the display device **100** according to the second example of the present disclosure, since the first inorganic film **310** is extended to the pad area PA, it is not required to arrange a mask for covering the pad electrode PAD on the pad electrode PAD so as not to form the first inorganic film **310** on the pad area PA. Therefore, in the display device **100** according to the second example of the present disclosure, a mask is not arranged on the pad electrode PAD to prevent arcing from being generated between a boundary surface of the mask and the pad electrode and prevent a defect from being generated due to a high current from the mask, which flows into the display device along the pad electrode PAD.

[0126] The organic film **320** is arranged on the first inorganic film **310**, and the second inorganic film **330** is arranged on the organic film **320**. The second inorganic film **330** is arranged to cover the organic film **320**. The second inorganic film **330** according to the second example of the present disclosure covers the organic film **320** and may be extended to the non-display area NDA to cover the dam DAM. At this time, the second inorganic film **330** according to the second example of the present disclosure is not formed on the pad area PA. That is, the first inorganic film **310** and the second inorganic film **330** according to the second example of the present disclosure are formed to have their respective ends located to be different from each other.

[0127] When forming the second inorganic film **330** according to the second example of the present disclosure, a mask may be arranged over the pad electrode PAD. At this time, in the display device **100** according to the second example of the present disclosure, since the first inorganic film **310** is formed on the pad electrode PAD, arcing is not generated between the boundary surface of the mask and the pad electrode PAD even though the mask is arranged over the pad electrode PAD. That is, the first inorganic film **310** serves as an insulating film between the mask and the pad electrode PAD. In this way, in the display device **100** according to the second example of the present disclosure, since the first inorganic film **310** formed to reach the pad area PA serves as an insulating film, arcing is not generated between the boundary surface of the mask and the pad electrode PAD even though the mask is arranged over the pad electrode PAD during a manufacturing process of the second inorganic film **330**.

[0128] In the display device **100** according to the second example of the present disclosure, a buffer layer is not formed on the encapsulation film **300**, and a bridge electrode BE is formed on the encapsulation film **300**. Although the buffer layer is formed on the encapsulation film **300** to protect the pad electrode PAD exposed when the bridge electrode BE is formed in the display device **100** according

to the first example of the present disclosure, the buffer layer is not required in the display device **100** according to the second example of the present disclosure because the pad electrode PAD is not exposed by the first inorganic film **310** when the bridge electrode BE is formed.

[0129] In the display device **100** according to the second example of the present disclosure, the bridge electrode BE is arranged on the encapsulation film **300**, and the insulating film **420** is arranged on the bridge electrode BE. The insulating film **420** is arranged to cover the bridge electrode BE, thereby insulating the bridge electrode BE from the first and second touch electrodes TE1 and TE2. The insulating film **420** according to the second example of the present disclosure covers the bridge electrode BE, and is extended to the non-display area NDA, whereby the insulating film may be formed to reach the pad area PA. Also, the insulating film **420** according to the second example of the present disclosure is extended to the pad area PA arranged outside the dam DAM but exposes the pad electrode PAD without covering the pad electrode PAD. At this time, the insulating film **420** according to the second example of the present disclosure surrounds the pad electrode PAD, and more specifically is arranged to surround the outside of the pad contact hole PCT for exposing the pad electrode PAD.

[0130] In the display device **100** according to the second example of the present disclosure, since the insulating film **420** is extended to the pad area PA, it is not required to arrange a mask for covering the pad electrode PAD on the pad electrode PAD so as not to form the insulating film **420** on the pad area PA.

[0131] The first inorganic film **310** and the insulating film **420** formed on the pad electrode PAD may be removed simultaneously to expose the pad electrode PAD during the process of forming the bridge contact hole BCT. That is, the bridge contact hole BCT and the pad contact hole PCT may be formed at the same time.

[0132] As described above, in the display device **100** according to the second example of the present disclosure, since the first inorganic film **310** is extended to the pad area PA, it is not required to arrange a mask for covering the pad electrode PAD on the pad electrode PAD so as not to form the first inorganic film **310** on the pad area PA.

[0133] Therefore, in the display device **100** according to the second example of the present disclosure, a mask is not arranged on the pad electrode PAD to prevent arcing from being generated between a boundary surface of the mask and the pad electrode and prevent a defect from being generated due to a high current from the mask, which flows into the display device **100** along the pad electrode PAD.

[0134] Also, in the display device **100** according to the second example of the present disclosure, since the pad electrode PAD is not exposed by the first inorganic film **310** when the bridge electrode BE is formed, it is not required to form the buffer layer. Therefore, the buffer layer is omitted in the display device **100** according to the second example of the present disclosure, whereby the manufacturing cost may be reduced and the process may be reduced.

[0135] FIG. 8 is a flow chart illustrating a method of manufacturing a display device according to the first example of the present disclosure, and FIGS. 9a to 9i are cross-sectional views illustrating a method of manufacturing a display device according to the first example of the present disclosure.

[0136] Plane views shown in FIGS. 9A to 9I relate to a method of manufacturing a display device according to the first example of the present disclosure shown in FIG. 6, and the same reference numerals are given to the same elements as those of FIG. 6. Hereinafter, the method of manufacturing a display device according to the first example of the present disclosure will be described with reference to FIG. 8 and FIGS. 9a to 9i.

[0137] First of all, as shown in FIG. 9A, pixels P are formed on the display area DA, and a pad electrode PAD and a dam DAM are formed on the non-display area NDA surrounding the display area DA (S801).

[0138] In more detail, an active layer 211 of a thin film transistor 210 is formed on a first substrate 111. In more detail, an active metal layer is formed on the entire surface of the first substrate 111 by a sputtering method or a MOVCD (Metal Organic Chemical Vapor Deposition) method. Then, the active metal layer is patterned by a mask process using a photoresist pattern to form the active layer 211. The active layer 211 may be formed of a silicon based semiconductor material or an oxide based semiconductor material.

[0139] Then, a gate insulating film 220 is formed on the active layer 211. The gate insulating film 220 may be formed of an inorganic film, for example, a silicon oxide film (SiO_x), a silicon nitride film (SiN_x) or a multi-layered film of the silicon oxide film and the silicon nitride film.

[0140] Then, a gate electrode 212 and a gate line 215 of the thin film transistor 210 are formed on the gate insulating film 220. Specifically, a first metal layer is formed on the entire surface of the gate insulating film 220 by a sputtering method or a MOVCD method. Then, the first metal layer is patterned by a mask process using a photoresist pattern to form the gate electrode 212 and the gate line 215. The gate electrode 212 and the gate line 212 may be formed of a single layer or multi-layer comprised of any one of Mo, Al, Cr, Au, Ti, Ni, Nd and Cu or their alloy.

[0141] Then, an inter-layer dielectric film 230 is formed on the gate electrode 212. The inter-layer dielectric film 230 may be formed of an inorganic film, for example, a silicon oxide film (SiO_x), a silicon nitride film (SiN_x), or a multi-layered film of the silicon oxide film and the silicon nitride film.

[0142] Then, contact holes for exposing the active layer 211 by passing through the gate insulating film 220 and the inter-layer dielectric film 230 and contact holes for exposing the gate line 215 by passing through the inter-layer dielectric film 230 are formed.

[0143] Then, source and drain electrodes 213 and 214, a source-drain line 216 and a pad electrode PAD of the thin film transistor 210 are formed on the inter-layer dielectric film 230. Specifically, a second metal layer is formed on the entire surface of on the inter-layer dielectric film 230 by a sputtering method or a MOVCD method. Then, the second metal layer is patterned by a mask process using a photoresist pattern to form the source and drain electrodes 213 and 214, the source-drain line 216 and the pad electrode PAD. Each of the source and drain electrodes 213 and 214 may be connected to the active layer 211 through contact holes that pass through the gate insulating film 220 and the inter-layer dielectric film 230. Also, the source-drain line 216 and the pad electrode PAD may be connected to the gate line 215 through contact holes that pass through the inter-layer dielectric film 230. Each of the source and drain electrodes

213 and 214, the source-drain line 216 and the pad electrode PAD may be formed of a single layer or multi-layer comprised of any one of Mo, Al, Cr, Au, Ti, Ni, Nd and Cu or their alloy.

[0144] Then, a planarization film 240 for planarizing a step difference due to the thin film transistor 210 is formed on the source and drain electrodes 213 and 214 of the thin film transistor 210. The planarization film 240 may be formed of an organic film such as acrylic resin, epoxy resin, phenolic resin, polyamide resin, and polyimide resin.

[0145] Then, an organic light emitting diode 250 is formed on the planarization film 240. Specifically, a first electrode 251 of the organic light emitting diode 250 is formed on the planarization film 240. More specifically, a third metal layer is formed on the entire surface of the planarization film 240 using a sputtering method or a MOVCD method. Then, the third metal layer is patterned by a mask process using a photoresist pattern to form the first electrode 251. The first electrode 251 may be connected to the source electrode 213 of the thin film transistor 210 through a contact hole that passes through the planarization film 240. The first electrode 251 may be formed of a conductive material with high reflexivity such as a deposition structure (Ti/Al/Ti) of Al and Ti, a deposition structure (ITO/Al/ITO) of Al and ITO, an APC alloy, or a deposition structure (ITO/APC/ITO) of APC alloy and ITO.

[0146] Then, in order to partition the pixels P, a bank 260 is formed on the planarization film 240 to cover an edge of the first electrode 251, and a dam DAM is also formed together with the bank 260. In this case, the dam DAM is formed on the non-display area NDA. Each of the dam DAM and the bank 260 may be formed of an organic film such as acrylic resin, epoxy resin, phenolic resin, polyamide resin, and polyimide resin.

[0147] Meanwhile, the dam DAM is formed simultaneously with the bank 260 but is not limited to this example. The dam DAM may be formed simultaneously with the planarization film 250.

[0148] Then, an organic light emitting layer 252 is formed on the first electrode 251 and the bank 260 by a deposition process or a solution process. Then, the second electrode 253 is formed on the organic light emitting layer 252. The second electrode 253 may be a common layer that is commonly formed on the pixels P. The second electrode 253 may be formed of a transparent conductive material (TCO) such as ITO and IZO, which may transmit light. The second electrode 253 may be formed by physics vapor deposition such as a sputtering method. A capping layer may be formed on the second electrode 253.

[0149] Secondly, as shown in FIG. 9B, a first inorganic film 310 is formed on the entire surface of the first substrate 111 (S802).

[0150] The first inorganic film 310 according to the first example of the present disclosure covers the second electrode 253, and is extended to the non-display area NDA to cover the dam DAM and the pad electrode PAD. In the display device 100 according to the first example of the present disclosure, since the first inorganic film 310 is extended to the pad area PA, it is not required to arrange a mask for covering the pad electrode PAD on the pad electrode PAD so as not to form the first inorganic film 310 on the pad area PA. Therefore, in the display device 100 according to the first example of the present disclosure, a mask is not arranged on the pad electrode PAD to prevent

arcing from being generated between a boundary surface of the mask and the pad electrode and prevent a defect from being generated due to a high current from the mask, which flows into the display device along the pad electrode PAD.

[0151] Thirdly, as shown in FIG. 9C, an organic film 320 and a second inorganic film 330 are formed on the first inorganic film 310 (S803).

[0152] The organic film 320 is formed to cover the first inorganic film 310. The organic film 320 may be formed with a sufficient thickness to prevent particles from being permeated into the organic light emitting layer 252 and the second electrode 253 by passing through the first inorganic film 310.

[0153] The second inorganic film 320 is formed to cover the organic film 320. Specifically, the mask for covering the pad electrode PAD is arranged over (but not on) the pad electrode PAD, whereby the second inorganic film 330 is formed except an upper portion of the pad electrode PAD.

[0154] Each of the first and second inorganic films 310 and 330 may be formed of a silicon oxide, a silicon nitride, a silicon oxynitride, an aluminum oxide, an aluminum nitride, a zirconium nitride, a titanium nitride, a hafnium nitride, a tantalum nitride, or a titanium oxide. The organic film 320 may be formed of acrylic resin, epoxy resin, phenolic resin, polyamide resin, or polyimide resin.

[0155] Fourthly, as shown in FIG. 9D, a photoresist (PR) pattern is formed on the first substrate 111 except the pad area PA (S804).

[0156] Fifthly, as shown in FIG. 9E, the first inorganic film 301 formed on the pad electrode PAD is removed (S805).

[0157] In detail, a dry etching process is performed on the first substrate 111 on which the photoresist pattern is formed. The first inorganic film 310 of the pad area PA where the photoresist pattern is not formed is removed by the dry etching process, and the pad electrode PAD is exposed. Then, the photoresist pattern is removed.

[0158] Sixthly, as shown in FIG. 9F, a buffer layer 410 is formed on the entire surface of the first substrate 111 (S806).

[0159] The buffer layer 410 according to the first example of the present disclosure covers the encapsulation film 300, and is extended to the non-display area NDA to cover the dam DAM and the pad electrode PAD. In the display device 100 according to the first example of the present disclosure, since the buffer layer 410 is formed to be extended to the pad area PA, the pad electrode PAD may be prevented from being damaged when the bridge electrode BE is formed on the buffer layer 410. In more detail, the bridge electrode BE is formed on the buffer layer 410, and in this case, if the pad electrode PAD is exposed, the pad electrode PAD may be damaged. In the display device 100 according to the first example of the present disclosure, the buffer layer 410 is formed to be extended to the pad area PA, and the bridge electrode BE is formed, whereby the pad electrode PAD may be prevented from being damaged.

[0160] Seventhly, as shown in FIG. 9G, the bridge electrode BE is formed on the buffer layer 410, and the insulating film 420 is entirely formed on the first substrate 111 (S807).

[0161] In detail, a fourth metal layer is formed on the entire surface of the buffer film 410 by a sputtering method or a MOVCD method. Then, the fourth metal layer is patterned by a mask process using a photoresist pattern to form the bridge electrode BE.

[0162] Then, the insulating film 420 is formed on the entire surface of the first substrate 111. The insulating film 420 according to the first example of the present disclosure covers the bridge electrode BE, and is extended to the non-display area NDA to cover the dam DAM and the pad electrode PAD. In the display device 100 according to the first example of the present disclosure, since the insulating film 420 is extended to the pad area PA, it is not required to arrange a mask for covering the pad electrode PAD on the pad electrode PAD so as not to form the insulating film 420 on the pad area PA.

[0163] Eighthly, as shown in FIG. 9H, a bridge contact hole BCT for exposing the bridge electrode BE and a pad contact hole PCT for exposing the pad electrode PAD are formed (S808).

[0164] The bridge contact hole BCT for exposing the bridge electrode BE by passing through the insulating film 420 and the pad contact hole PCT for exposing the pad electrode PAD are formed at the same time.

[0165] The buffer layer 410 and the insulating film 420 formed on the pad electrode PAD may be removed simultaneously to expose the pad electrode PAD during the process of forming the bridge contact hole BCT.

[0166] The bridge electrode BE may be connected to first touch electrodes TE1 through the bridge contact hole BCT, which passes through the insulating film 420, to electrically connect the first touch electrodes TE1.

[0167] Ninthly, as shown in FIG. 9I, the first touch electrode TE1, a second touch electrode TE2 and touch lines TL1 and TL2 are formed, the first touch electrode E1 is electrically connected with the bridge electrode BE and the pad electrode PAD, and a passivation film 430 is formed (S809).

[0168] In detail, the first touch electrodes TE1, the second touch electrodes TE2 and the touch lines TL1 and TL2 are formed on the buffer layer 410. The first touch electrodes TE1 are arranged in a first direction to be spaced apart from each other at a constant space, and the second touch electrodes TE2 are arranged in a second direction to be connected to each other. In this case, each of the first touch electrodes TE1 and the second touch electrodes TE2 may have shapes of a rectangle, an octagon, a circle, or a rhombus.

[0169] Among the first touch electrodes TE1 connected with each other in the first direction, the first touch electrode TE1 arranged at one end may be connected to the first touch line TL1 on the non-display area NDA. The first touch line TL1 may be extended from the first touch electrode TE1 and then patterned to reach the pad area PA. The first touch electrode TE1 and the first touch line TL1 may be formed on the same layer, and may be formed of the same material.

[0170] Among the second touch electrodes TE2 connected with each other in the second direction, the second touch electrode TE2 arranged at one end may be connected to the second touch line TL2 on the non-display area NDA. The second touch line TL2 may be extended from the second touch electrode TE2 and then patterned to reach the pad area PA. The second touch electrode TE2 and the second touch line TL2 may be formed on the same layer, and may be formed of the same material.

[0171] The first touch electrodes TE1, the second touch electrodes TE2, the first touch lines TL1, and the second

touch lines TL2 may be formed of a transparent conductive material (TCO) such as ITO and IZO, which may transmit light.

[0172] A fifth metal layer is formed on the entire surface of the insulating film 420 by a sputtering method or a MOVCD method. Then, the fifth metal layer is patterned by a mask process using a photoresist pattern to form the first touch electrodes TE1, the second touch electrodes TE2, the first touch lines TL1, and the second touch lines TL2.

[0173] Then, a passivation film 430 is formed on the first touch electrode TE1 and the second touch electrode TE2.

[0174] Although not shown in detail, the first substrate 111 where the passivation film 430 is formed is bonded to the second substrate 112. The first substrate 111 and the second substrate 112 may be bonded to each other in such a manner that the passivation film 430 of the first substrate 111 and the second substrate 112 are adhered to each other using an adhesive layer (not shown). The adhesive layer (not shown) may be an optically clear resin (OCR) or an optically clear adhesive film (OCA).

[0175] In the display device 100 according to the first example of the present disclosure, since the first inorganic film 310 is extended to the pad area PA, it is not required to arrange a mask for covering the pad electrode PAD on the pad electrode PAD so as not to form the first inorganic film 310 on the pad area PA. Therefore, in the display device 100 according to the first example of the present disclosure, a mask is not arranged on the pad electrode PAD to prevent arcing from being generated between a boundary surface of the mask and the pad electrode and prevent a defect from being generated due to a high current from the mask, which flows into the display device along the pad electrode PAD.

[0176] FIG. 10 is a flow chart illustrating a method of manufacturing a display device according to the second example of the present disclosure, and FIGS. 11a to 11f are cross-sectional views illustrating a method of manufacturing a display device according to the second example of the present disclosure.

[0177] Plane views shown in FIGS. 11A to 11F relate to a method of manufacturing a display device according to the second example of the present disclosure shown in FIG. 7, and the same reference numerals are given to the same elements as those of FIG. 7. Hereinafter, the method of manufacturing a display device according to the second example of the present disclosure will be described with reference to FIG. 10 and FIGS. 11A to 11F.

[0178] First of all, as shown in FIG. 11A, pixels P are formed on the display area DA, and a pad electrode PAD and a dam DAM are formed on the non-display area NDA surrounding the display area DA (S1101).

[0179] Secondly, as shown in FIG. 11b, a first inorganic film 310 is entirely formed on the first substrate 111 (S1102).

[0180] Thirdly, as shown in FIG. 11C, an organic film 320 and a second inorganic film 330 are formed on the first inorganic film 310 (S1103).

[0181] The method of manufacturing a display device 100, which is shown in FIGS. 11A to 11C, is the same as the method of manufacturing a display device 100 according to the first example described with reference to FIGS. 9A to 9C. Therefore, repeated description of the same elements will be omitted.

[0182] Fourthly, as shown in FIG. 11D, the bridge electrode BE is formed on the buffer layer 410, and the insulating film 420 is formed on the entire surface of the first substrate 111 (S1004).

[0183] In the display device 100 according to the second example of the present disclosure, the buffer layer is not formed on the encapsulation film 300, and the bridge electrode BE is formed on the encapsulation film 300. Although the buffer layer is formed on the encapsulation film 300 to protect the pad electrode PAD exposed when the bridge electrode BE is formed in the display device 100 according to the first example of the present disclosure, the buffer layer is not required in the display device 100 according to the second example of the present disclosure because the pad electrode PAD is not exposed by the first inorganic film 310 when the bridge electrode BE is formed. Therefore, the buffer layer is omitted in the display device 100 according to the second example of the present disclosure, whereby the manufacturing cost may be reduced and the process may be reduced.

[0184] According to the process of forming the bridge electrode BE, a fourth metal layer is formed on the entire surface of the second inorganic film 330 by a sputtering method or a MOVCD method. Then, the fourth metal layer is patterned by a mask process using a photoresist pattern to form the bridge electrode BE.

[0185] Then, the insulating film 420 is formed on the entire surface of the first substrate 111. The insulating film 420 according to the second example of the present disclosure covers the bridge electrode BE, and is extended to the non-display area NDA to cover the dam DAM and the pad electrode PAD. In the display device 100 according to the second example of the present disclosure, since the insulating film 420 is extended to the pad area PA, it is not required to arrange a mask for covering the pad electrode PAD on the pad electrode PAD so as not to form the insulating film 420 on the pad area PA.

[0186] Fifthly, as shown in FIG. 11E, a bridge contact hole BCT for exposing the bridge electrode BE and a pad contact hole PCT for exposing the pad electrode PAD are formed (S1005).

[0187] The bridge contact hole BCT for exposing the bridge electrode BE by passing through the insulating film 420 and the pad contact hole PCT for exposing the pad electrode PAD by passing through the insulating film 420 are formed at the same time.

[0188] The bridge electrode BE may be connected to first touch electrodes TE1 through the bridge contact hole BCT, which passes through the insulating film 420, to electrically connect the first touch electrodes TE1.

[0189] Sixthly, as shown in FIG. 11F, the first touch electrode TE1, a second touch electrode TE2 and touch lines TL1 and TL2 are formed, the first touch electrode TE1 is electrically connected with the bridge electrode BE and the pad electrode PAD, and a passivation film 430 is formed (S1006).

[0190] The method of manufacturing a display device 100, which is shown in FIG. 11E, is the same as the method of manufacturing a display device 100 according to the first example described with reference to FIG. 9I. Therefore, repeated description of the same elements will be omitted.

[0191] In the display device 100 according to the second example of the present disclosure, since the first inorganic film 310 is formed to be extended to the pad area PA, it is

not required to arrange a mask for covering the pad electrode PAD on the pad electrode PAD so as not to form the first inorganic film 310 on the pad area PA.

[0192] Therefore, in the display device 100 according to the second example of the present disclosure, a mask is not arranged on the pad electrode PAD to prevent arcing from being generated between a boundary surface of the mask and the pad electrode and prevent a defect from being generated due to a high current from the mask, which flows into the display device along the pad electrode PAD.

[0193] Also, in the display device 100 according to the second example of the present disclosure, since the pad electrode PAD is not exposed by the first inorganic film 310 when the bridge electrode BE is formed, it is not required to form the buffer layer. Therefore, the buffer layer is omitted in the display device 100 according to the second example of the present disclosure, whereby the manufacturing cost may be reduced and the process may be reduced.

[0194] As described above, according to the present disclosure, the following advantages may be obtained.

[0195] In the display device according to the first example of the present disclosure, since the first inorganic film is formed to be extended to the pad area PA, it is not required to arrange a mask for covering the pad electrode on the pad electrode so as not to form the first inorganic film on the pad area PA.

[0196] Therefore, in the display device according to the first example of the present disclosure, a mask is not arranged on the pad electrode to prevent arcing from being generated between a boundary surface of the mask and the pad electrode and prevent a defect from being generated due to a high current from the mask, which flows into the display device along the pad electrode.

[0197] Also, in the display device according to the second example of the present disclosure, since the buffer layer is omitted, the manufacturing cost may be reduced and the process may be reduced.

[0198] It will be apparent to those skilled in the art that various modifications and variations can be made without departing from the scope of the present disclosure. Thus, it is intended that the present disclosure covers the modifications and variations of this disclosure provided they come within the scope of the appended claims and their equivalents.

What is claimed is:

1. A display device comprising:

a first substrate where a display area and a non-display area are defined, wherein a plurality of pixels are arranged at the display area and the non-display area surrounds the display area;

a dam surrounding the display area and arranged at the non-display area;

an organic light emitting diode provided in the display area;

an encapsulation film disposed on the organic light emitting diode;

a buffer layer disposed on the encapsulation film;

an insulating film disposed on the buffer layer;

a pad area arranged outside the dam, wherein the buffer layer and the insulating film extend from the display area to the pad area;

a link line disposed between the dam and the first substrate; and

a routing line provided on the insulating layer between the display area and the pad area.

2. The display device of claim 1, wherein the link line is a source-drain line.

3. The display device of claim 1, wherein the link line is formed of the same material as at least one of a source electrode and a drain electrode.

4. The display device of claim 1, wherein the routing line is a touch line.

5. The display device of claim 1, wherein the encapsulation film extends from the display area to the non-display area to form a side surface of the encapsulation film, wherein the routing line extends over the encapsulation film side surface.

6. The display device of claim 1, wherein the pad area includes a pad electrode.

7. The display device of claim 6, wherein the routing line contacts the pad electrode through a pad contact hole in the pad area.

8. The display device of claim 7, wherein the pad contact hole passes through the insulating layer and a first inorganic film of the encapsulation film.

9. The display device of claim 6, wherein the pad electrode is formed of the same material as the link line.

10. The display device of claim 6, wherein the pad electrode is connected to the link line by a gate line.

11. The display device of claim 10, further comprising a thin film transistor formed on the substrate in the display area,

wherein the thin film transistor includes an active layer, a gate electrode, a source electrode, a drain electrode, a gate insulating film, and an inter-layer dielectric film, and

wherein the pad electrode and the link line contact the gate line through a contact hole passes through the inter-layer dielectric film.

12. The display device of claim 11, wherein the gate line and the gate electrode are disposed on the same layer.

13. The display device of claim 12, wherein the gate line and the gate electrode are disposed on the gate insulating film.

14. The display device of claim 1, wherein the gate line is provided between the dam and the pad area.

15. The display device of claim 1, wherein the encapsulation film includes a first inorganic film disposed on the dam.

16. The display device of claim 1, wherein the encapsulation film includes a first inorganic film extending to the pad electrode.

17. The display device of claim 16, wherein the encapsulation film further includes an organic film arranged on the first inorganic film.

18. The display device of claim 17, wherein the encapsulation film further includes a second inorganic film arranged on the organic film, wherein the first and second inorganic films have their respective ends located to be different from each other.

19. The display device of claim 17, wherein the encapsulation film further includes an organic film arranged on the first inorganic film and a second inorganic film arranged on the organic film, wherein the first and second inorganic films cover the dam.

20. The display device of claim 1, further comprising first touch electrodes arranged on the insulating film and electrically connected with a pad electrode in the pad area, wherein the insulating film surrounds the pad electrode.

* * * * *

专利名称(译)	显示装置及其制造方法		
公开(公告)号	US20190131379A1	公开(公告)日	2019-05-02
申请号	US16/176061	申请日	2018-10-31
[标]申请(专利权)人(译)	乐金显示有限公司		
申请(专利权)人(译)	LG DISPLAY CO. , LTD.		
当前申请(专利权)人(译)	LG DISPLAY CO. , LTD.		
[标]发明人	WON SANGHYUK KIM MINJOO LEE JAEWON PAK SANGHOON KIM BYONGHOO LEE SANGHEUN GWON HYANGMYOUNG LEE JEONGHOON KIM SUNGJIN JANG JAEHYUNG LEE YUNA		
发明人	WON, SANGHYUK KIM, MINJOO LEE, JAEWON PAK, SANGHOON KIM, BYONGHOO LEE, SANGHEUN GWON, HYANGMYOUNG LEE, JEONGHOON KIM, SUNGJIN JANG, JAEHYUNG LEE, YUNA		
IPC分类号	H01L27/32 H01L51/52		
CPC分类号	H01L27/3276 H01L51/5284 H01L51/5253 H01L27/323 H01L27/3246 G06F3/0412		
优先权	1020170143995 2017-10-31 KR		
外部链接	Espacenet USPTO		

摘要(译)

一种显示装置，包括：第一基板，其中限定显示区域和非显示器，其中多个像素布置在显示区域，非显示区域围绕显示区域；围绕显示区域并安排的非显示区域的坝；显示区域内设有有机发光二极管；封装膜设置在有机发光二极管上；缓冲层设置在封装膜上；绝缘膜设置在缓冲层上；布置在坝体外部的焊盘区域，其中缓冲层和绝缘膜从显示区域延伸到焊盘区域；设置在挡板和第一基板之间的连接线；以及在显示区域和焊盘区域之间的绝缘层上提供的布线。

